



NEW

C72 SE

evo

Professional balancing machine with pneumatic locking



www.rustehnika.ru



Ergonomic design

3D

Sonar automatic measurement

VDD

Virtual Direct Drive
(CEMB patent)

IC[®]

Intelligent Correction
(CEMB patent)

Options

Zero weight

Automatic lift

EMS

Wheel eccentricity

CEMB C72 *evo*

VDD
Virtual Direct Drive





NEW

C72 SE evo

Dedicated to all operators looking for a quick, accurate, simple and reliable machine

- Intelligent and automatic system to measure diameter and distance with Cemb gauge
- **SONAR LA device (Cemb Patent)** for automatic measurement of the wheel width
- **VDD** very quick measurement system, maintenance free (**Cemb Patent**)
- **Electric brake** to lock the wheel in the exact position
- **Locking** of the counterweight support gauge in the correction position for **ALU** wheels (**Cemb Patent**)

www.rustehnika.ru



- Multifunction digital display
- Menu for selecting options and customizations
- **IC concept**, reduction of residual vibrations on the vehicle
- Autodiagnosis and self-calibration
- **ALU-S** balancing mode (weights inside the rim) with specific counterweight position indicator



- **SPLIT** program to hide weight behind spokes



- New ergonomic cone and adapter holders



- **Sonar EMS** device (optional) for automatic measurement of the wheel radial eccentricity
- **Wheel pneumatic locking (Cemb patent)**
 - Mounting/demounting time reduction
 - Extremely easy and quick use
 - Accurate wheel centering guaranteed
 - Possibility to use traditional adapters (UH20)

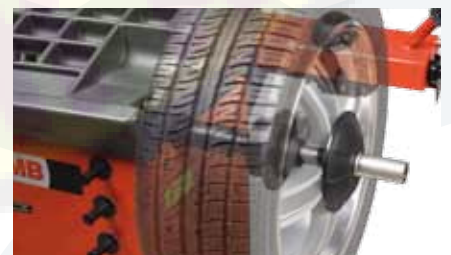

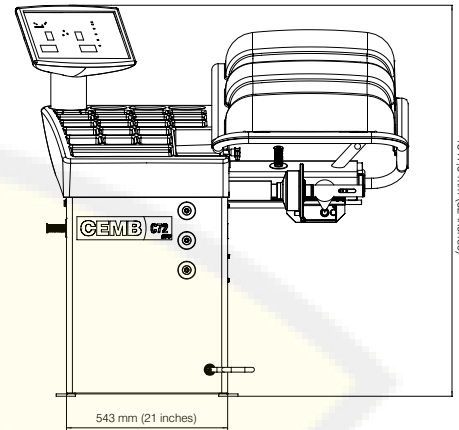
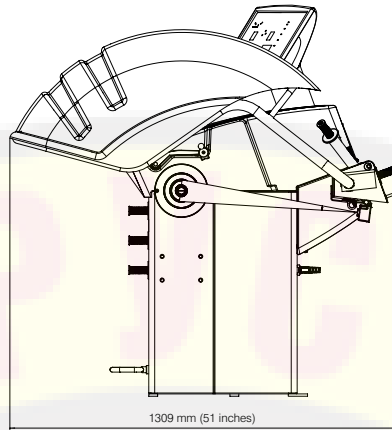

The balancing machine is also available with manual locking, (version C72evo), provided with foot brake.

Single phase power supply	115 / 230 V 50/60 Hz
Protection class	IP 54
Absorbed power	0,15 Kw
Balancing speed	100 min-1
Cycle time per wheel	4.7 seconds (5 3/4"x14") 15 Kg / 33 lbs
Max. resolution of measurement	1 gram / 0,04 oz
Position resolution	± 1.4 °
Average noise	< 70 dB (A)
Rim / machine distance	0 ÷ 255 mm / 0 ÷ 10"
Rim width setting range	1.5" ÷ 20" / 40 ÷ 510 mm
Settable diameter	10" ÷ 30" / 265 ÷ 765 mm
Min/max. compressed air pressure	8 ÷ 10 Kg/cm ² / 18 ÷ 22 lbs ~ 0.8 ÷ 1 Mpa; ~ 8 ÷ 10 BAR; ~ 115 ÷ 145 PSI.
Air consumption for wheel locking/unlocking	4 lt. (with 8 Kg/cm ²) / 1,06 gal us (with 18 lbs / in ²)
Machine weight	130 Kg / 287 lbs
Packaging	105x152x183h / 41"x60"x72"h

STANDARD ACCESSORIES

In 1932 Cemb created the cone adapters for balancing machines and since then the company continued developing and producing high precision centering systems for any type of wheel. Cemb does not recommend the use of non-original adapters on its balancing machines.

UC20/SE2 41FF52768

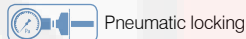

Pneumatic locking

Standard equipment composed of: 3 cones Ø 45÷110 mm, quick locking sleeve SE2, width gauge, pincer-hammer and 60 g counterweight



UC20/2 GL40 41FF83149



Manual locking

Standard equipment composed of: 3 cones Ø 45÷110 mm, quick locknut GL40, width gauge, pincer-hammer and 60 g counterweight



OPTIONAL ACCESSORIES Especially designed for car manufacturers



RL cup 41FF79255

Large plastic cup with polyurethane protection ring for light alloy rims.

VL/2 cone + G36 disc 41FF86174

Kit for light truck wheels (Ø97÷170mm central hole).

MT cone 40FF57321

High precision graduated cone for German cars (with central hole Ø56,5 / 57 / 66,5 / 72,5 mm).

UH20/2 41FF42048

Universal adapter for wheels with 3,4,5,6 holes (pitch circle Ø95-210 mm) complete with high precision back centering double cone for wheels with/without central hole (Renault, Peugeot and Citroën). Grants double accuracy compared to similar adapters on the market.

SR4 - SR4/SE - SR5 - SR5/SE SR5/2 SR5/2/SE - SRUSA - SR/USA/SE

Stud adapters for rim protection and high precision centering for wheels with 4 or 5 holes. Studs are made of two pieces, elastically coupled: pressure is therefore homogeneous on all the holes.

Mercedes kit 41FF88003

High precision kit : 3 cones (Ø57- Ø66,5 -Ø84/85mm) + 1 pressure spring, according to Mercedes Benz specifications.

Peugeot - Citroën kit 41FF73171

High precision kit: 1 bush Ø60mm + 2 cones (Ø62 ÷ 68 mm and Ø54 ÷ 60 mm). Developed according to Peugeot and Citroën specifications.

Renault kit 41FF77152

High precision kit : 5 bushes (Ø60 / 66 / 71 / 88 / 129,9 mm). Developed according to Renault specifications.

For more information see the complete brochure on the web site www.cemb.com

Option to increase your profitability ZERO WEIGHT Lift

ZERO WEIGHT

Zero gravity effect
Wheel loading and removal without effort or adjustment

PERFECT CENTERING

Wheel automatic lifting
Ideal centering and more accurate balancing

QUICK

Quicker than any other traditional lift
A single pedal controls the whole working cycle

AUTOMATIC

Electronic system with PLC

UNIVERSAL

Applicable to any balancing machine



Some of our customers:

FERRARI • MASERATI • LAMBORGHINI •
MERCEDES-BENZ • BMW • VOLKSWAGEN • FIAT •
LANCIA • ALFA ROMEO • FORD NISSAN • RENAULT
• HARLEY DAVIDSON • HONDA • YAMAHA • SUZUKI
• KAWASAKI • KTM • DUCATI • TRIUMPH • APRILIA -
PIAGGIO • MOTO GUZZI • PIRELLI • BRIDGESTONE
• MICHELIN • CONTINENTAL • DUNLOP •
GOODYEAR • BREMBO • METZELER



CEMB

BALANCING MACHINES



CEMB S.p.A.

Via Risorgimento, 9
23826 Mandello del Lario (LC) Italy
www.cemb.com



Garage equipment division

CEMB - ITALY

Plant and Training Center

phone +39 0341 706369
fax +39 0341 700725
garage@cemb.com

CEMB USA

BL Systems Inc.

2873 Ramsey Road
Gainesville, GA 30501 - USA
Phone +001 678 717 1050
Fax +001 678 717 1056
sales@cemb-usa.com

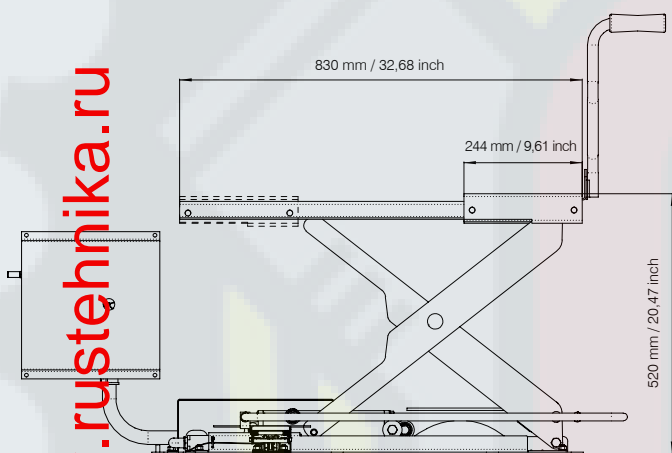

For more information see the complete brochure on the web site www.cemb.com

www.rustehnika.ru

Cemb technology



ITALIAN HEART: All parts which influence the quality of our balancers are manufactured within Cemb through appropriate machinery. The tolerances used are the most accurate on the market. Only in this way it is possible to maintain a constant and accurate balancing through time.

VDD - New: Defined as a "Maintenance Free" concept, it allows maximum accuracy in minimum time, increasing reliability and features of all Cemb balancers. This has been possible thanks to a new patented system of measurement (both mechanical and electronic) as a result of Cemb's unique experience in the field of industrial balancing and vibration analysis instrumentation. With the VDD even the most economic Cemb balancer wins against any of its competitors in both speed and accuracy.



CEMB FOR THE ENVIRONMENT

Our machines save much more energy than you would think! We care for the environment, as much as we care for your costs: these are our priorities. Save money! Save the environment!

Buy our machines.

Ask for more details, we are at your full disposal.



All the data and features mentioned in this catalogue are purely for information and do not constitute any commitment on the part of our company, which reserves the right to make any and all alterations it may consider suitable without notice.