

LC112.00.00

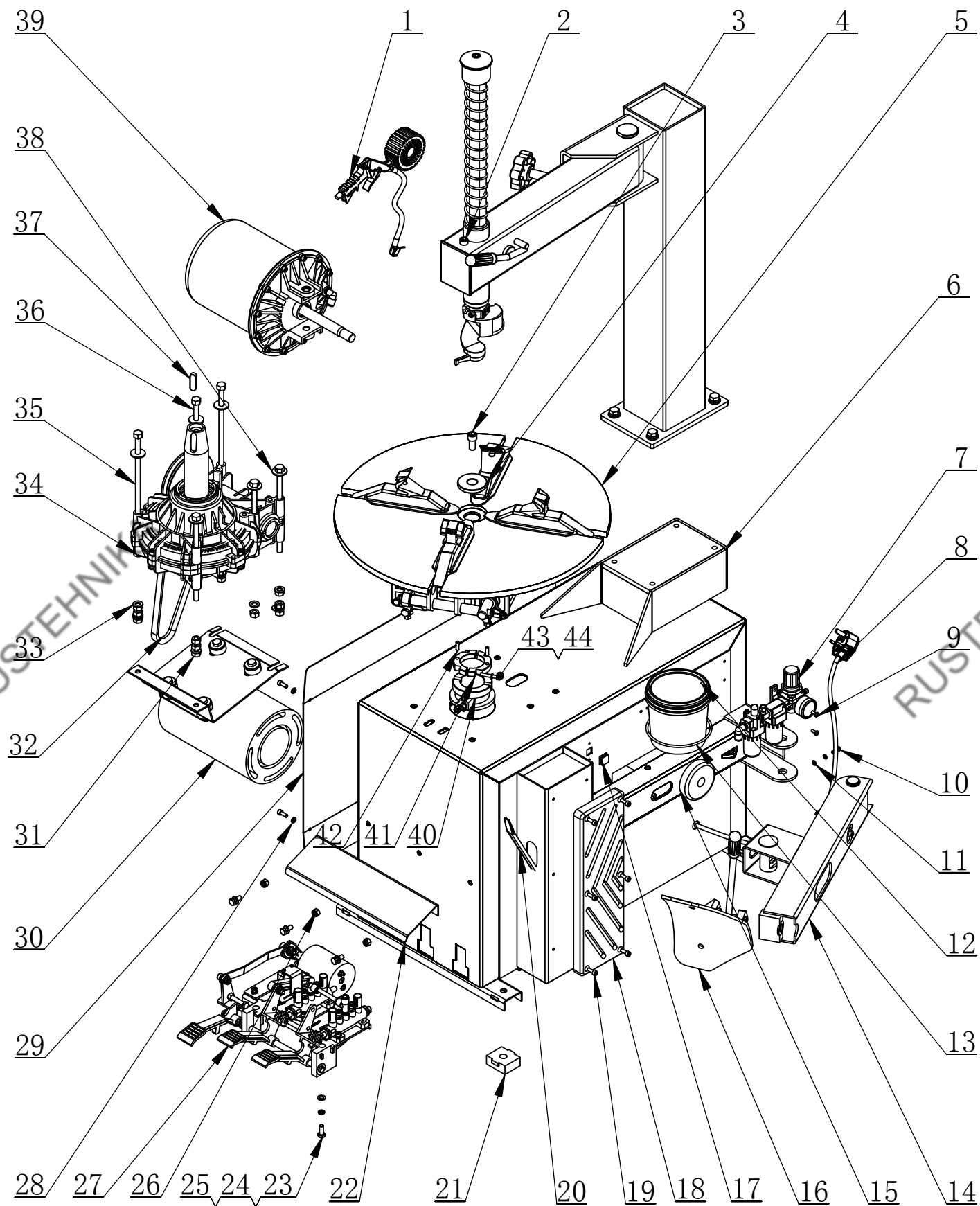

ITEM	QTY.	PART NO.	DESCRIPTION.
1	1	5004098	INFLATING GUN
2	1	6004537	TILTING ARM ASSEMBLY
3	1	5010032	SCREW M12X25
4	1	6000106	PRESS WASHER
5	1	6000100	TURNTABLE ASSEMBLY
6	1	6004526	BODY
7	1	5506002	AIR REGULATOR ASEMBLY
8	1	5004107	CABLE PLUG
9	2	5006007	SCREW M5X12
10	1	5006042	BOLT M5X16
11	2	5010045	WASHER 5
12	1	5004093	GREASE CONTAINER
13	1	5004092	BRACKET
14	1	6000358	BEAD BREAKER ARM ASSEMBLY
15	1	5004073	RUBBER PLATE
16	1	6000012	BEAD BREAKER BLADE
17	1	5004103	RUBBER BLOCK
18	1	5004218	RIM SUPPORT
19	10	5010074	SCREW M6X16-N
20	1	5004094	CROWBAR
21	4	5004102	RUBBER FOOT
22	1	6004531	PROTECTIVE COVER
23	5	5010077	BOLT M8X20
24	5	5004046	WASHER 8
25	5	5000018	WASHER 8
26	3	5002060	NUT M8
27	1	6000230	PEDAL ASSEMBLY
28	4	5000007	WASHER 6
29	1	6004530	SIDE PANEL
30	1	6000180	MOTOR ASSEMBLY
31	14	5010004	NUT M10
32	1	5502039	BELT A26
33	14	5006005	WASHER 10
34	1	6000351	GEARBOX ASSEMBLY
35	4	5004006	BOLT M10X200
36	2	5004004	BOLT M10X160
37	1	5006044	PLAIN KEY 12x40
38	6	5004005	WASHER 10
39	1	6000020	BEAD BREAKER CYLINDER ASSEMBLY
40	1	6000619	AIR GUIDER ASSEMBLY
41	1	6000618	CLAMP RING
42	2	5006040	SCREW M6X20-N
43	2	5004031	SCREW M6X35
44	2	5010058	WASHER 6

TILTING ARM ASSEMBLY

REVISION A-01

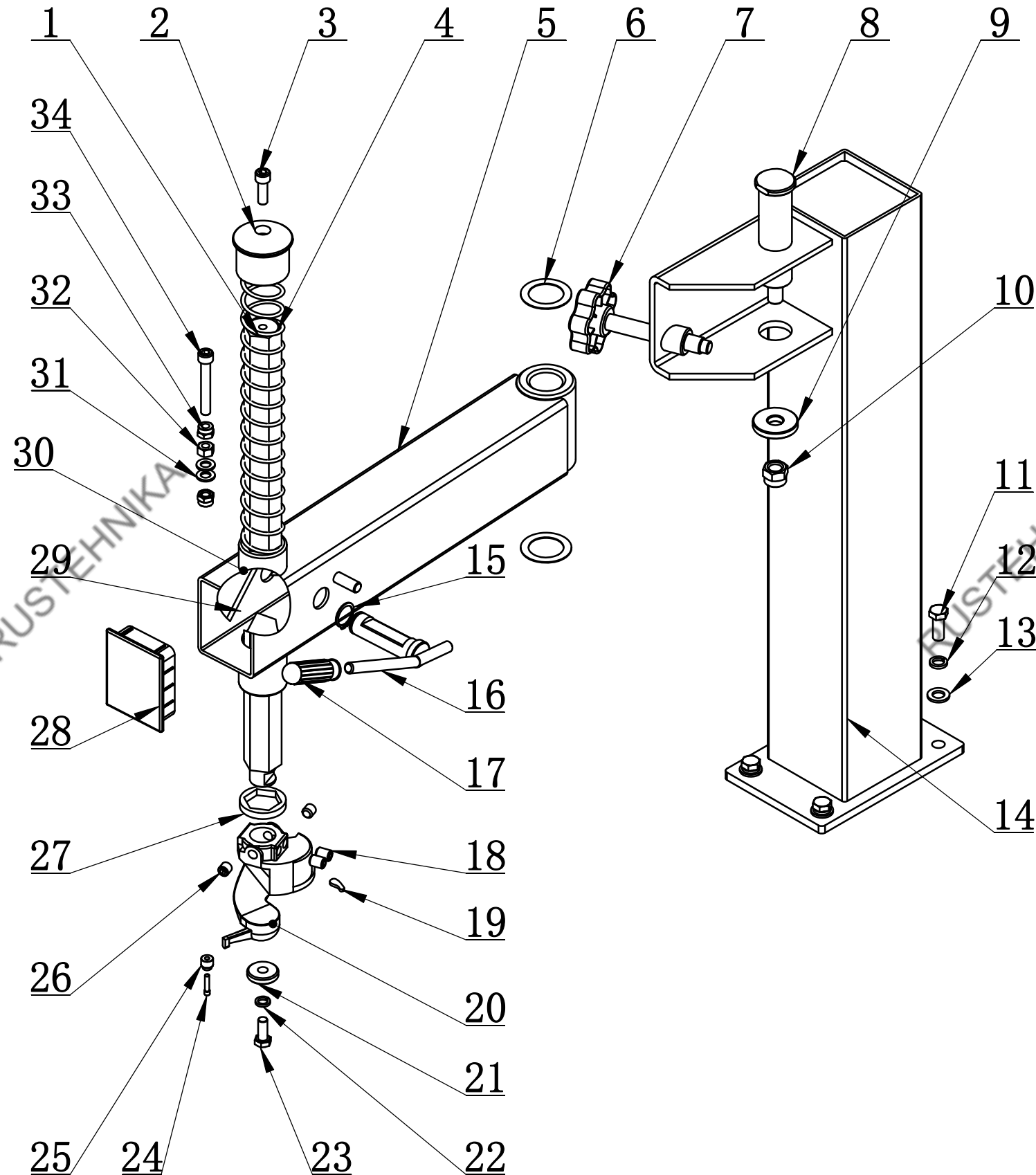

ITEM	QTY.	PART NO.	DESCRIPTION.
1	1	6005017	HEXAGON SHAFT
2	1	5004200	VERTICAL SHAFT COVER
3	1	5000033	SCREW M10X30
4	1	6005011	VERTICAL SHAFT SPRING
5	1	6005016	SWING ARM
6	2	6005027	ADJUSTING WASHER
7	1	5502048	HANDLE WHEEL
8	1	6005014	VERTICAL SHAFT
9	1	6010036	VERTICAL SHAFT WASHER
10	1	5004215	NUT M16
11	4	5006041	BOLT M12X30-N
12	4	5010025	WASHER 12
13	4	5010020	WASHER 12
14	1	6004532	VERTICAL COLUMN
15	1	5002030	CIRCLIP 25
16	1	6010042	LOCK HANDLE
17	1	6008091	RUBBER COVER
18	2	5004023	SCREW M12X16-N
19	1	5502044	PLASTIC COVER
20	1	5004118	DEMOUNTING HEAD
21	1	5004201	PRESS WASHER
22	1	5010006	WASHER 10
23	1	5004020	BOLT M10X25
24	1	5004116	SCREW 6x25
25	1	5004117	ROLLER
26	2	5004021	SCREW M12X12-N
27	1	5004115	SHOCK ABSORBER WASHER
28	1	6005018	DECORATING COVER
29	1	5502053	HEXAGON LOCKING PLATE
30	1	5502052	VERTICAL SHAFT SPRING
31	2	5006005	WASHER 10
32	1	5010004	NUT M10
33	2	5006001	NUT M10
34	1	5000034	SCREW M10X70-N

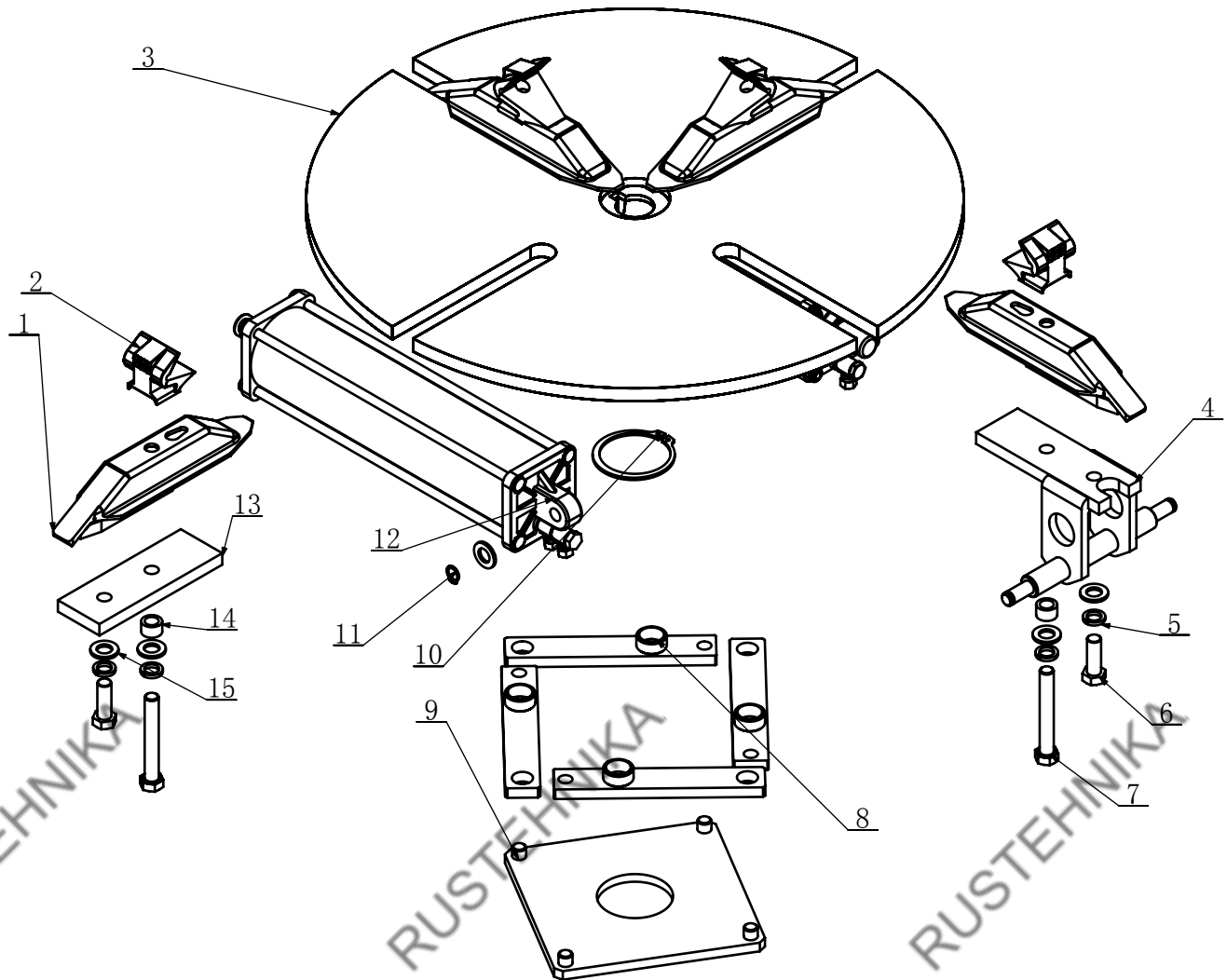

ITEM	QTY.	PART NO.	DESCRIPTION.
1	4	6000101	SLIDE COVER
2	4	6000107	CLAMP
3	1	6000102	TURNTABLE
4	2	6000103	CYLINDER BRACKET
5	8	5010025	WASHER 12
6	4	5010033	BOLT M12X35
7	4	5010127	BOLT M12X85
8	4	6000104	CONNECTION PLATE
9	1	6000105	SQUARE TURNTABLE
10	1	5010030	CIRCLIP 65
11	4	5010034	CIRCLIP 12
12	2	6000087	CYLINDER ASSEMBLY
13	2	6000108	PRESS PLATE
14	4	6000109	SPACER
15	12	5010020	WASHER 12

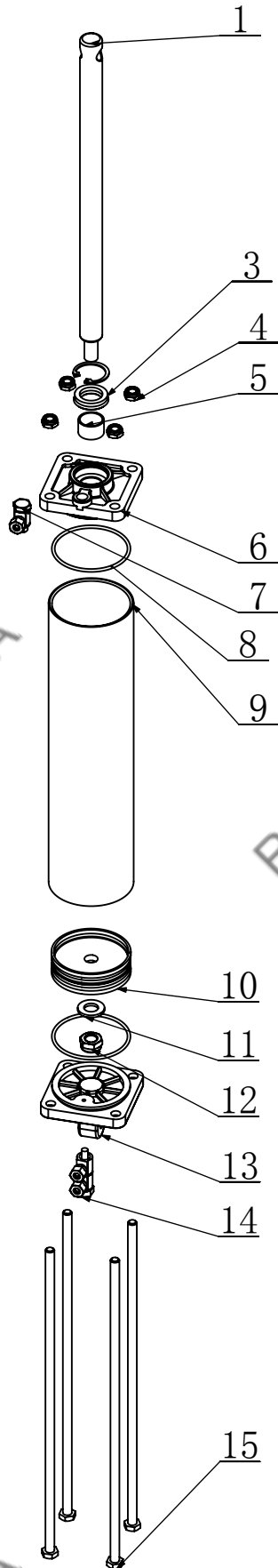

ITEM	QTY.	PART NO	DESCRIPTION.
1	1	6000006	SHAFT-CLYNDR
2	1	5010105	CIRCLIP 30
3	1	6000007	SEAL-ROD,CYLNDR
4	4	5010003	NUT M8
5	1	6000008	BEARING-SLIDE
6	1	6000004	CAP-TOP,CYLNDR
7	1	6000009	HINGE ELBOW
8	2	5010021	SEAL-O RING 65X2.65
9	1	6000002	SLEEVE-CYLNDR 70
10	1	6000011	PISTON-W/WSHR,ASSY
11	1	5000021	WASHER 12
12	1	5010022	NUT M12
13	1	6000003	CAP-BASE,CYLNDR
14	1	6000010	HINGE TEE
15	4	6000005	BOLT

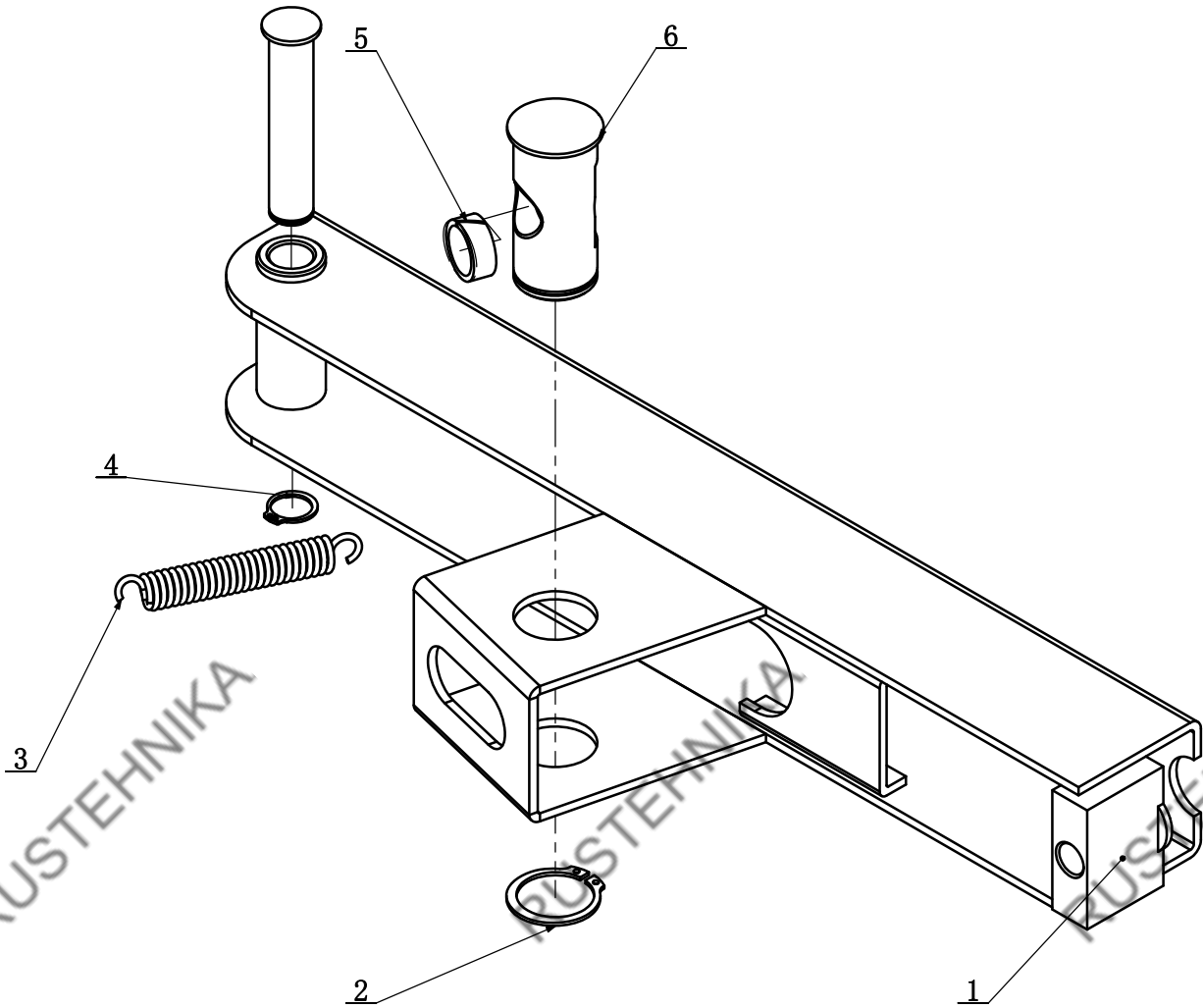

ITEM	QTY.	PART NO.	DESCRIPTION.
1	1	6000359	BEAD BREAKING ARM ASSEMBLY
2	1	5010116	CIRCLIP 34
3	1	6000360	Spring
4	1	5010211	CIRCLIP 18
5	1	6000344	SLIDE SPACER
6	1	6000361	BEAD BREAKING ARM SLIDE BUSHING
7	1	5506001	BEAD BREAKING ARM BACK PIN SHAFT

6000230 FOOT PEDAL ASSEMBLY

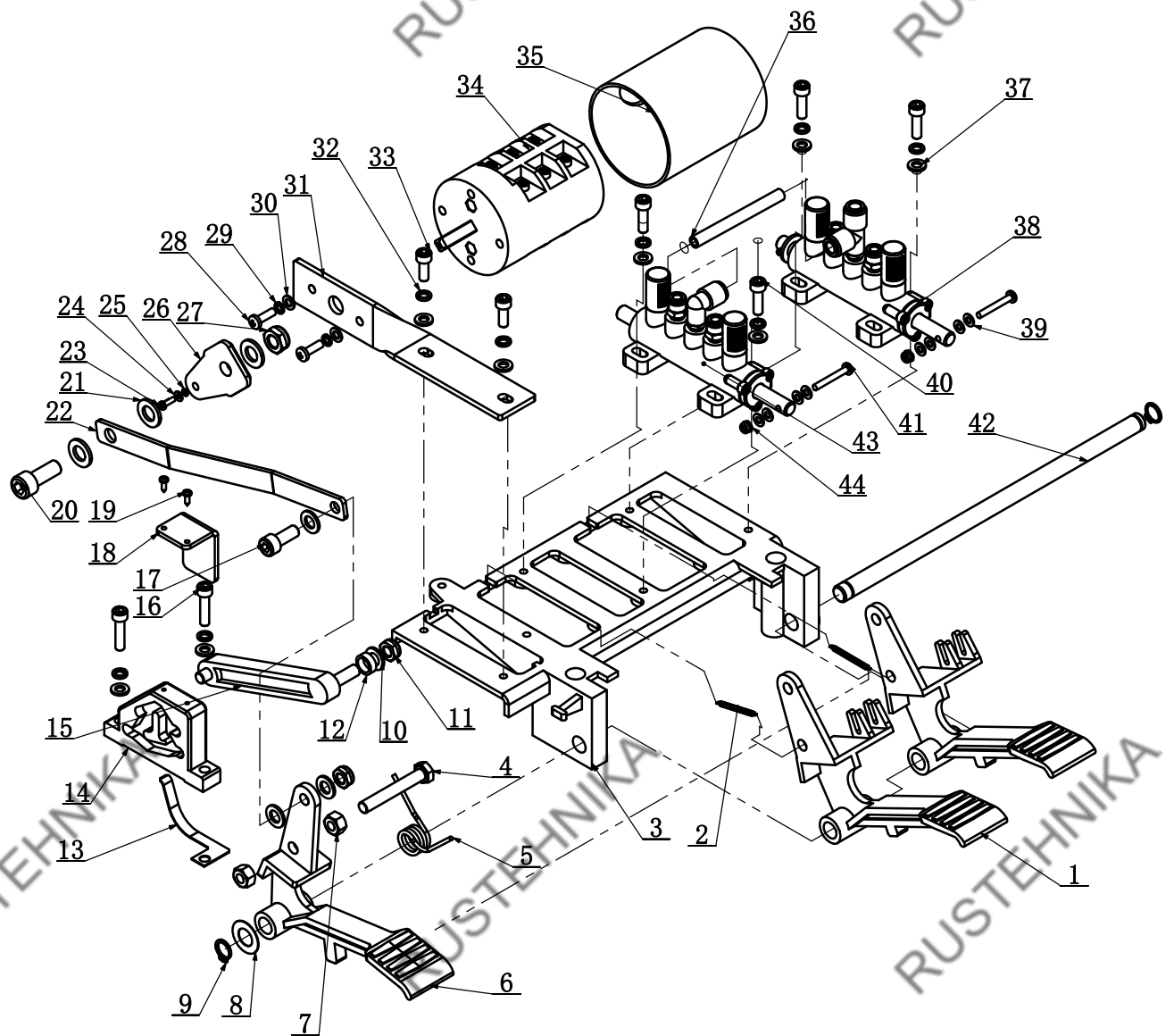

ITEM	QTY.	PART NO.	DESCRIPTION.	ITEM	QTY.	PART NO.	DESCRIPTION.
1	2	6000231	PEDAL	23	1	5010065	SCREWS M3X10
2	2	6000236	EXT.SPRING,PEDAL	24	1	5004033	WASHER_PWNA 3
3	1	6000233	BRACKET-VLVE,SWTCH	25	1	5000079	SPRING LOCK WASHER 3
4	1	5004035	BOLT M8X55	26	1	6000212	REVERSE LEVER
5	1	6000241	SPRING-TRSN	27	1	5010043	NUT M10
6	1	6000232	PEDAL A	28	2	5011004	SCREWS M5X16
7	2	5002060	NUT M8	29	2	5004045	WASHER 5
8	2	6000228	WASHER-12x0.5	30	2	5010045	WASHER 5
9	2	5010061	CIRCLIP 12X1	31	1	6000243	SWITCH BASE LATE
10	4	5000018	WASHER 8	32	8	5010058	WASHER 6
11	2	5010003	NUT M8	33	2	5010074	SCREW M6X16-N
12	1	6000205	PENDING VALAVE PURREUL	34	1	5010055	SWITCH
13	1	6000237	SPRING PLATE	35	1	6000215	SWITCH COVER
14	1	6000211	CAM	36	1	5010049	HOSE 8-5MM
15	1	6000226	VALVE CONNECTING ROD	37	8	5000007	WASHER 6
16	2	5006006	SCREW M6X25	38	1	6000244	VALVE A
17	1	5010063	SCREW M8X20	39	8	5010040	WASHER 4
18	1	6000217	CAM PLATE	40	4	5004032	SCREW M6X20-N
19	2	5010057	SCREW ST2.9X9.5	41	2	5010066	SCREWS M4X30
20	1	5010064	SCREW M10X25	42	1	6000234	SHAFT-RTTN,PDL
21	3	5006005	WASHER 10	43	1	6000245	VALVE B
22	1	6000235	SWITCH CONNECT PLATE	44	2	5010067	NUT M4

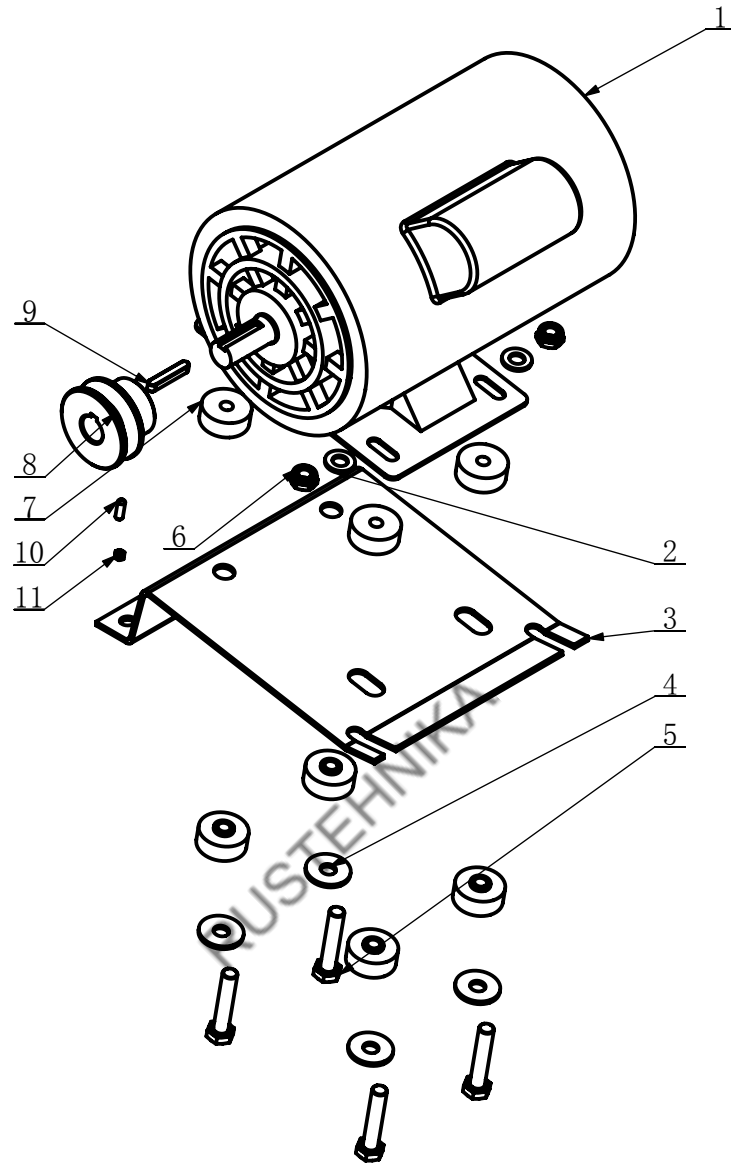
6000180 MOTOR ASSEMBLY

ITEM	QTY.	PART NO.	DESCRIPTION.
1	1	6000181	MOTOR AC220V, 1.1kW, 50Hz
2	4	5004041	WASHER 10
3	1	6000182	MOTOR SUPPORT
4	4	5004005	WASHER 10
5	4	5010041	BOLT M10X50
6	4	5010043	NUT M10
7	8	6000183	RUBBER WASHER
8	1	6000184	MOTOR BELT PULLEY
9	1	5010056	PLAIN KEY 6X36
10	1	5010232	SCREW M5X16
11	1	5011008	NUT M5

6000351 GEARBOX ASSEMBLY

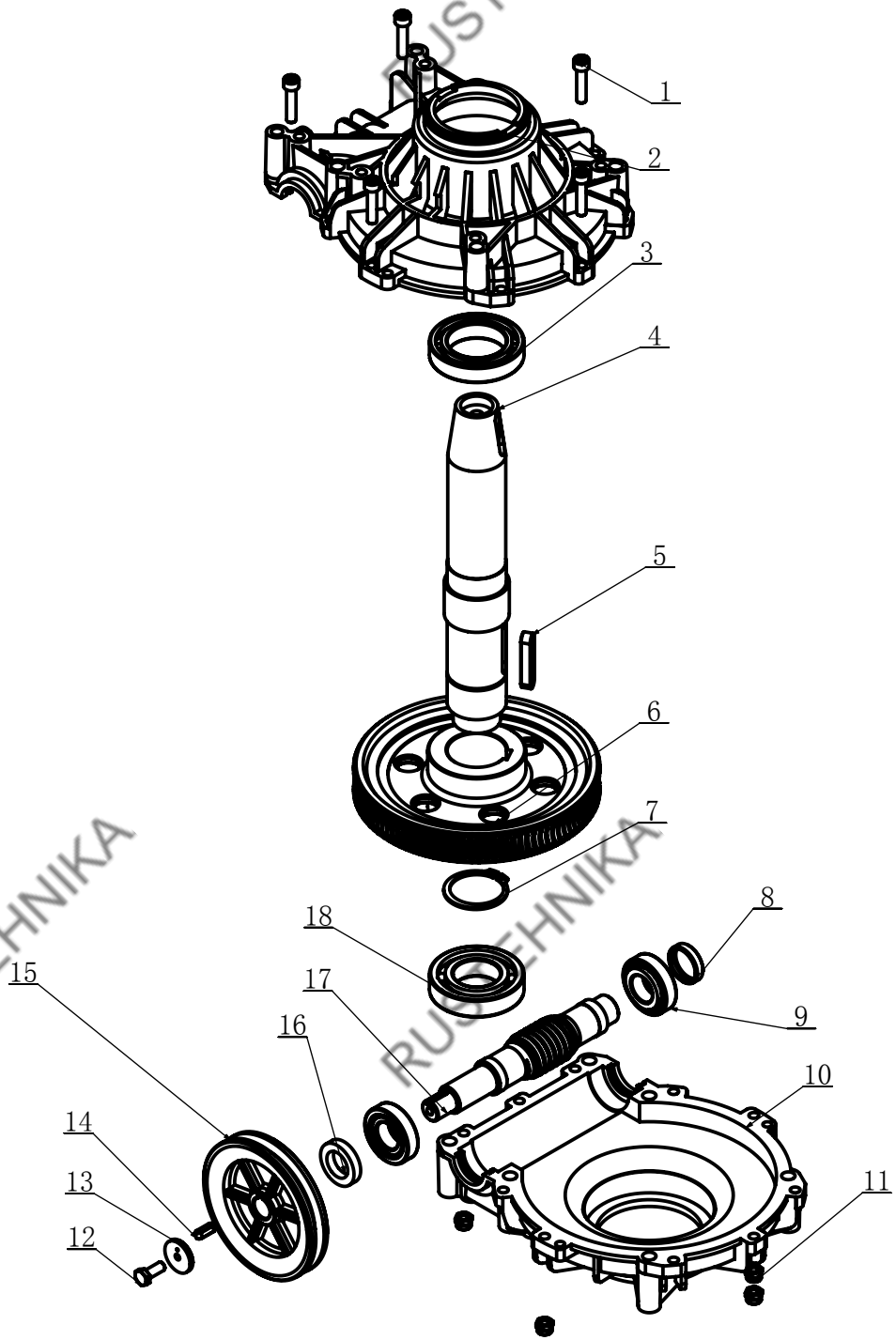

ITEM	QTY.	PART NO.	DESCRIPTION.
1	5	5010209	SCREW M8X35
2	1	6000353	GEARBOX TOP
3	1	5010002	ROLLING BEARING 6010
4	1	6000352	WORM SHAFT
5	1	5010111	PLAIN KEY 12X55
6	1	6000354	WORM
7	1	5010001	CIRCLIP 50
8	1	6000355	CAP 40X25X8
9	2	5000015	ROLLING BEARING 30205
10	1	6000356	GEARBOX BASE
11	5	5010092	PREVAILING TORQUE M8
12	1	5010077	BOLT M8X20
13	1	5010210	RING 30
14	1	5010080	PLAIN KEY 6X20
15	1	6000275	BELT PULLEY
16	1	5010208	SEAL
17	1	6000273	WORM ROD
18	1	5010076	BEARING 6208

600020 BEAD BREAKING CYLINDER ASSEMBLY

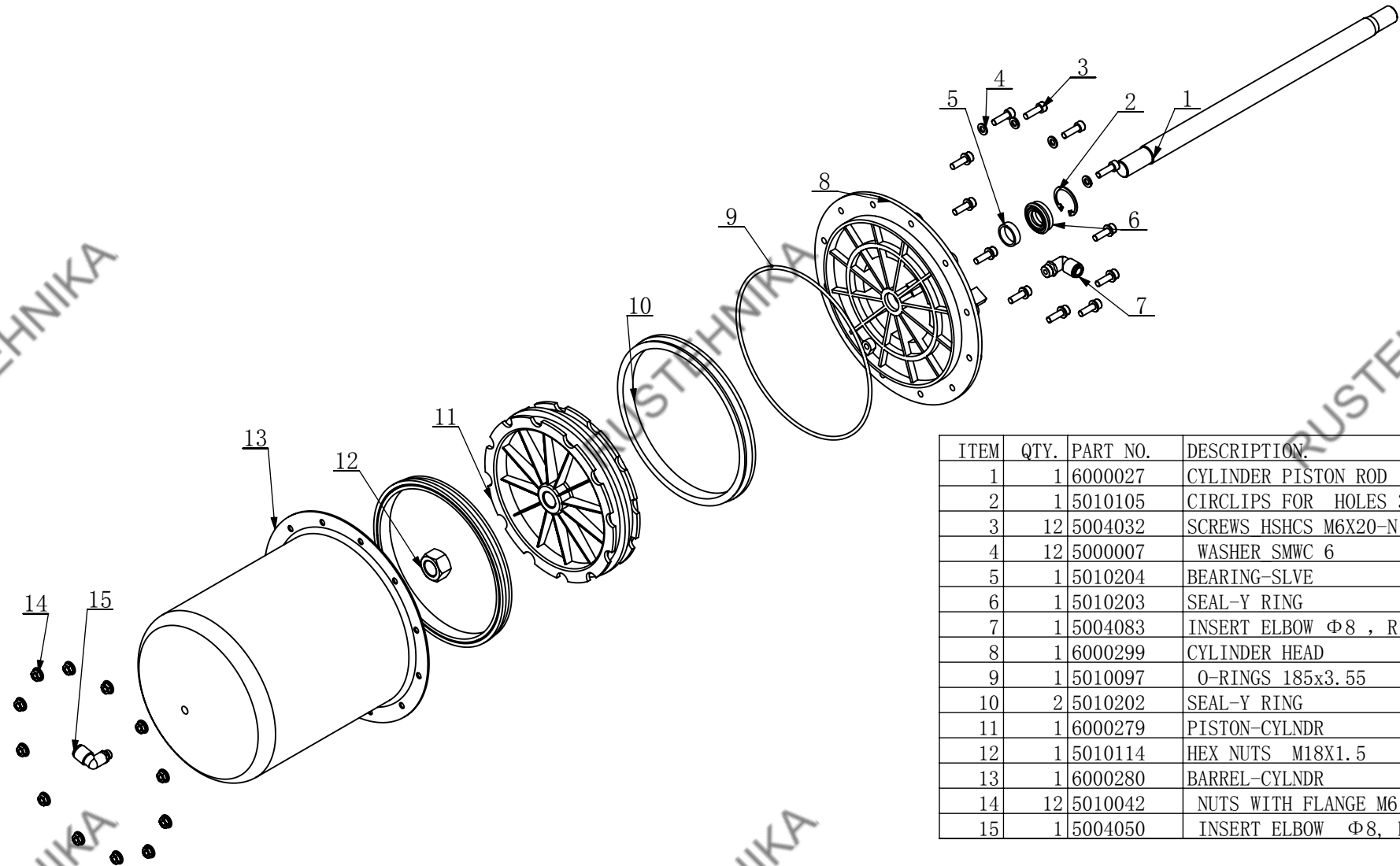

ITEM	QTY.	PART NO.	DESCRIPTION.
1	1	6000027	CYLINDER PISTON ROD
2	1	5010105	CIRCLIPS FOR HOLES 30
3	12	5004032	SCREWS HSHCS M6X20-N
4	12	5000007	WASHER SMWC 6
5	1	5010204	BEARING-SLVE
6	1	5010203	SEAL-Y RING
7	1	5004083	INSERT ELBOW $\Phi 8$, R1/4"
8	1	6000299	CYLINDER HEAD
9	1	5010097	O-RINGS 185x3.55
10	2	5010202	SEAL-Y RING
11	1	6000279	PISTON-CYLNDR
12	1	5010114	HEX NUTS M18X1.5
13	1	6000280	BARREL-CYLNDR
14	12	5010042	NUTS WITH FLANGE M6
15	1	5004050	INSERT ELBOW $\Phi 8$, R1/8"

5506002

AIR REGULATOR ASEMBLY

REVISION A-02

ITEM	QTY.	PART NO.	DESCRIPTION.
1	1	5004083	INSERT ELBOW $\Phi 8$, R1/4"
2	1	5004087	OIL CUP
3	1	5006052	LOCK NUT
4	1	5006051	TEE
5	1	5004086	WATER CUP
6	1	5004085	BRACKET
7	1	6004514	ADJUSTING VALVE
8	1	5004079	AIR SUPPLY CONNECTOR
9	1	5004081	PRESSURE GAUGE

