

# 25-2

Capacity 25.000 kg

# 50-2

Capacity 50.000 kg

# 25-2TH

Capacity 25.000 kg

# 50-2TH

Capacity 50.000 kg



**DK Brugermanual**  
Lufthydraulisk donkraft

**GB User's guide**  
Air-hydraulic Jack

**DE Betriebsanleitung**  
Lufthydraulischer Heber

- DK
- NO
- GB
- DE
- FR
- FI
- SE
- NL
- ES



**AC Hydraulic A/S**  
 Fanøvej 6  
 DK-8800 Viborg - Danmark  
 Tel.: +45 8662 2166  
 Fax: +45 8662 2988  
 E-mail: ac@ac-hydraulic.dk  
[www.ac-hydraulic.com](http://www.ac-hydraulic.com)

0825029-160627

**GB** **25-2, 50-2,**  
**25-2TH, 50-2TH**

**WARNINGS - safe use instructions**

1. Study, understand and follow all instructions before operating this jack.
2. Do not exceed rated capacity.
3. Use only on hard level surface.
4. It is recommended to brake and chock the vehicle.
5. Lifting device only. Immediately after lifting, support the vehicle with support stands.
6. Lift only on areas of the vehicle as specified by the vehicle manufacturer, and only centrally on the lifting saddle.
7. No person should remain in, on, or get bodily under a load that is being jacked or is supported only by a jack.
8. Do not use more than 2 standard extensions in sequence.
9. No alterations shall be made to this jack.
10. Maximum air pressure: 12 bar/170 psi.
11. Failure to follow these warnings may result in personal injury and/or property damage.

**Assembly**

To mount the handle turn the jack upside down.

**IMPORTANT:** The hoses must be twisted around the tube as shown on the photo.

**WARNING:** Do not operate the jack in this position or lying on the side - if so there is risk of oil spillage.

Oil mechanical parts before first use.

Air connection: 1/4" WRG.

Full capacity from 9 bar/125 psi. Maximum air pressure: 12 bar/170 psi.

**Use of the jack**

**Transport:** The jack is to be stored or transported standing on its wheels. If need be the jack may be transported lying on the left side observed from the handle side, but in this case a little oil spillage from the air motor might occur.

**Lifting:** turn the control valve clockwise until the pump starts.

**Lowering:** turn the control valve counter clockwise. Always lower the jack completely in order to protect the lifting cylinder.

**The handle** offers 3 different positions: pull the handle and tip as required.

**Maintenance**

Maintenance and repair must always be carried out by qualified personnel.

The air-motor requires oil to lubricate the mechanical parts. It is recommended to use air supply with water separator/filter and oil lubricator.

**Daily:** Lubricate the air-motor by injecting a little oil into the air connection on the handle and then lift to max. position. Disconnect the air hose, inject further oil into the air connection, reconnect the air hose and turn the control valve counter clockwise to lubricate the cylinder walls.

**Monthly:** Empty water separator/filter and fill oil lubricator with oil. Lubricate all mechanical parts with a few drops of oil. At the same time inspect jack and extensions for damage and wear and tear.

**Oil level:** refill oil through hole (9) on left-hand side of cabinet. Correct oil level is to the lower edge of the hole with the jack horizontal and the cylinder completely lowered.

**Quantity of oil:** 2,5 l.

Use high quality hydraulic oil, viscosity ISO VG 15.

**Never use brake fluid!**

**Safety Inspection**

According to national legislation - minimum once a year though - the jack must be inspected by a professional: Damages, wear of cylinder bottom below plug 0258400, wear and tear, adjustment of the safety valve, cylinder and pump for leakages. Furthermore that all safety labels are legible.

**Troubleshooting**

1. The jack does not lift to maximum position even though the air motor is running: refill with oil.
2. The air motor runs slowly or stops: the air filter (handle drawing, no. 8) in the air connection is blocked and needs cleaning or changing.
3. The load is dropping: change valve cores in pump. **PLEASE OBSERVE** that the valve cores are to be tightened slightly only: tighten to a torque setting of 10 Nm).
4. The cylinder is leaking: Change cylinder seals. A sudden oil leak from air motor or handle might be caused by wrong handling, e.g. if the jack has been lying on the side. If so the oil leak (from the reservoir) will stop, when the jack is standing on the wheels again - but oil drips will continue for a while.

**Spare parts**

Replace worn or broken parts with genuine jack manufacturer supplied parts only. All major parts may not be provided after discontinuation of a model.

**Destruction**

Oil must be drained off and legally disposed of.

# 25-2, 50-2, 25-2TH, 50-2TH

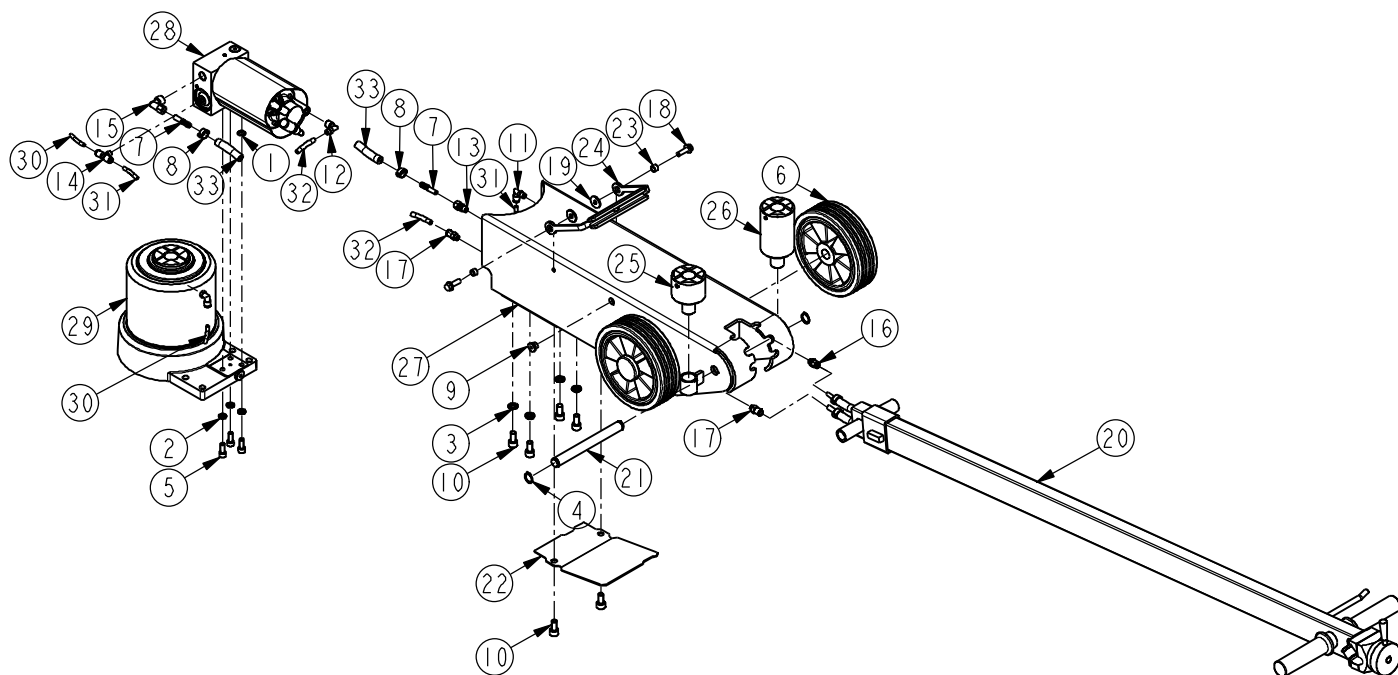

- Ⓚ Montering af slanger
- Ⓜ Mounting of hoses
- Ⓓ Montage von Schläuchen

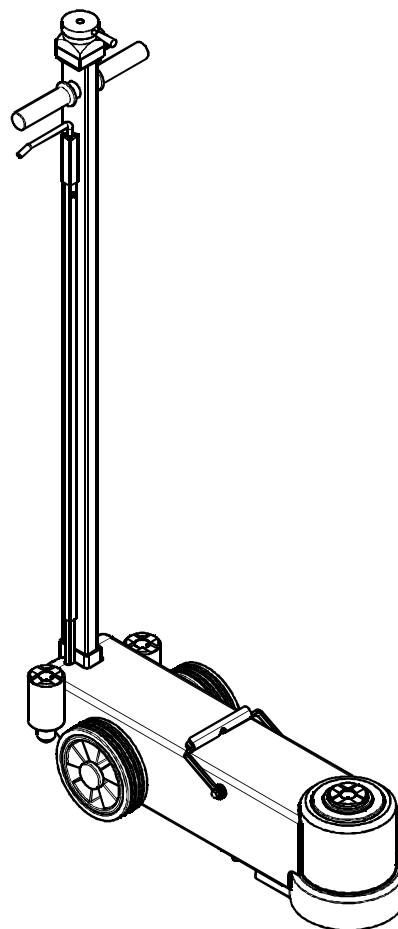
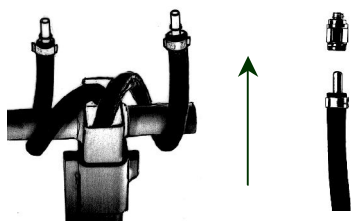

	25-2	50-2	(DK)	(GB)	(DE)	
Pos.	Art. No.	Art. No.	Pcs.	Benævnelse	Description	Bezeichnung
	<b>44 400 00</b>	<b>44 200 00</b>		<b>Donkraft</b>	<b>Air-hydraulic jack</b>	<b>Lufthydraulischerheber</b>
	<b>44 500 00</b>	<b>44 300 00</b>		<b>Donkraft med teleskophåndtag</b>	<b>Air-hydraulic jack with telescopic handle</b>	<b>Lufthydraulischerheber mit Teleskophebel</b>
1	01 000 00	01 000 00	1	O-ring	O-ring	O-ring
2	02 102 00	02 102 00	3	Skive	Washer	Scheibe
3	02 103 00	02 103 00	4	Skive	Washer	Scheibe
4	02 204 00	02 204 00	2	Seegerring	Circlip	Seegerring
5	02 306 00	02 306 00	3	Skruer	Screw	Schraube
6	02 518 00	02 367 00	2	Hjul	Wheel	Rad
7	02 418 00	02 418 00	2	Slangestuds	Hose union	Schlauchstuz
8	02 421 00	02 421 00	2	Slangeklemme	Hose clamp	Schlauchklemme
9	02 470 00	02 470 00	1	Prop	Plug	Füllpropfen
10	02 485 00	02 485 00	6	Skruer	Screw	Schraube
11	02 493 00	02 493 00	1	Fitting	Fitting	Fitting
12	02 495 00	02 495 00	1	Fitting	Fitting	Fitting
13	02 498 00	02 498 00	1	Forskruning	Gland	Verschraubung
14	02 505 00	02 505 00	1	Fitting	Fitting	Fitting
15	02 510 00	02 510 00	1	Fitting	Fitting	Fitting
16	02 512 00	02 512 00	1	Fitting	Fitting	Fitting
17	02 516 00	02 516 00	2	Fitting	Fitting	Fitting
18	02 520 00	02 520 00	2	Skruer	Screw	Schraube
19	02 766 00	02 766 00	2	Skive	Washer	Scheibe
<b>20</b>	<b>44 001 00</b>	<b>44 001 00</b>	<b>1</b>	<b>Håndtag</b>	<b>Handle</b>	<b>Hebel</b>
<b>20</b>	<b>44 101 00</b>	<b>44 101 00</b>	<b>1</b>	<b>Teleskophåndtag</b>	<b>Telescopic handle</b>	<b>Teleskophebel</b>
21	44 005 00	44 005 00	1	Aksel for håndtag	Axle for handle	Hebelachse
22	44 007 24	44 007 24	1	Beskyttelsesplade	Protection plate	Schutzplatte
23	44 008 00	44 008 00	2	Bøsning	Bushing	Buchse
24	44 009 03	44 009 03	1	Bærehåndtag	Carrying handle	Traghebel
25	44 016 00	44 016 00	1	Forlænger, 50 mm	Extension, 50 mm	Verlängerung 50 mm
26	44 017 00	44 017 00	1	Forlænger, 100 mm	Extension, 100 mm	Verlängerung 100 mm
27	44 407 00	44 207 00	1	Ramme	Frame	Rahmen
28	90 727 30	90 727 30	1	Pumpe	Pump	Pumpe
29	90 745 00	90 740 00	1	Cylinder	Cylinder	Zylinder
30	90 796 18	90 796 18	1	Luftslange	Air hose	Luftschlauch
31	90 796 35	90 796 35	1	Luftslange	Air hose	Luftschlauch
32	90 798 31	90 798 31	1	Luftslange	Air hose	Luftschlauch
33	90 880 45	90 880 45	1	Slange	Hose	Schlauch

90 727 30

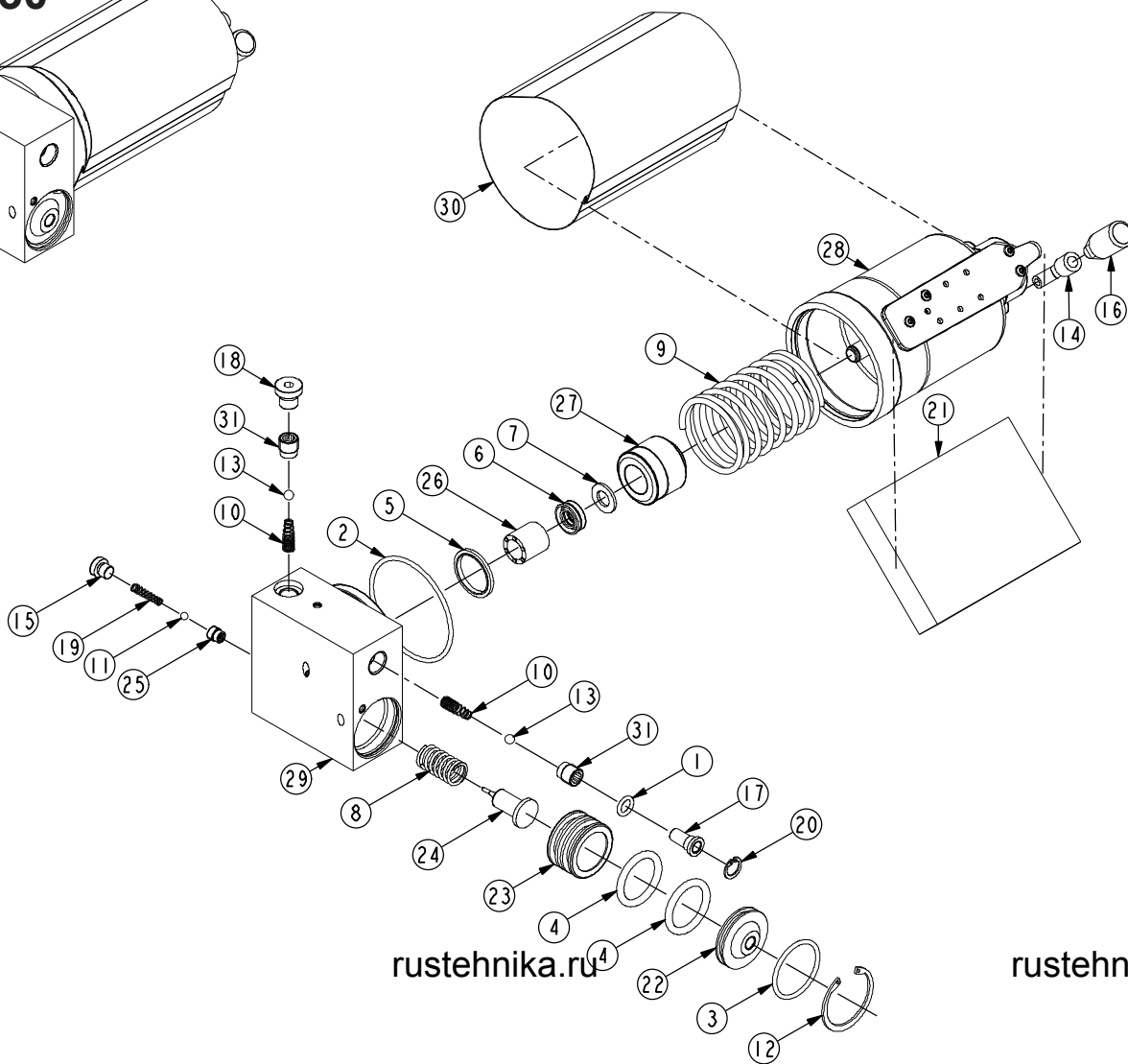
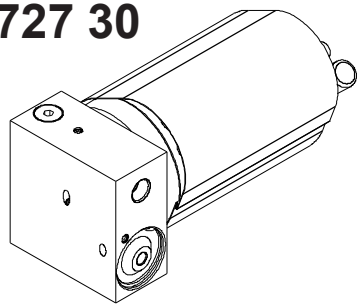

90 728 42

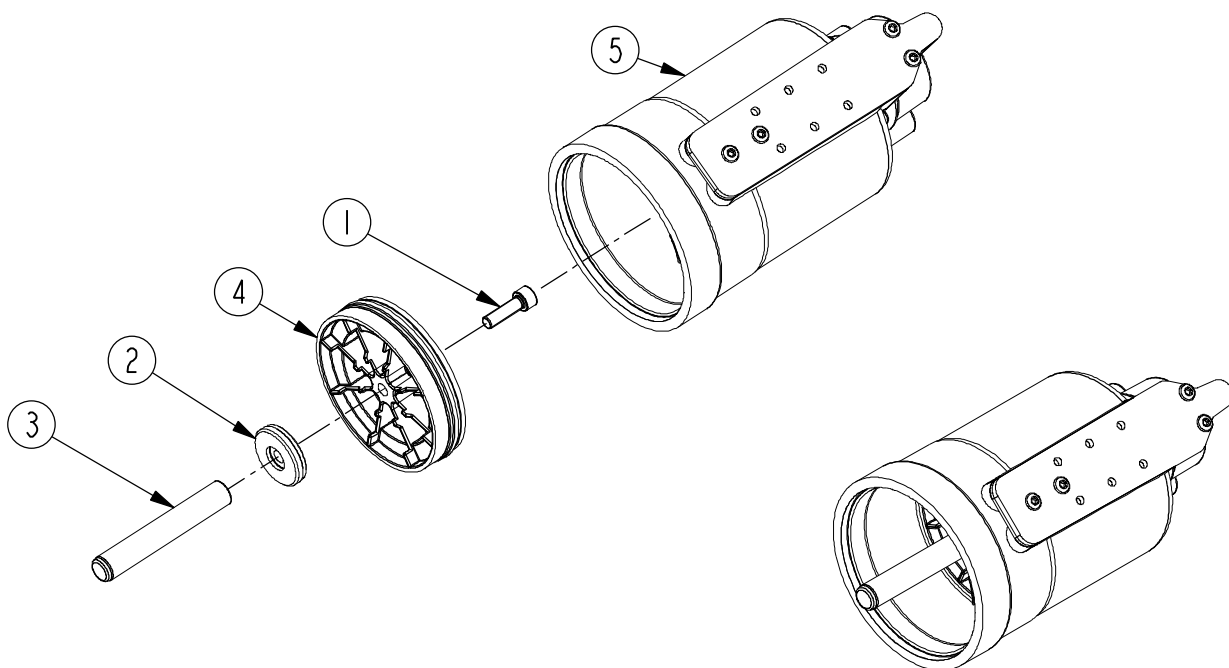

	25-2	50-2		(DK)	(GB)	(DE)
Pos.	Art. No.	Art. No.	Pcs.	Benævnelse	Description	Bezeichnung
	90 727 30	90 727 30		Pumpe, komplet	Pump, complete	Pumpe, komplett
*1	01 000 00	01 000 00	1	O-ring	O-ring	O-ring
*2	01 007 00	01 007 00	1	O-ring	O-ring	O-ring
*3	01 034 00	01 034 00	1	O-ring	O-ring	O-ring
*4	01 044 00	01 044 00	2	O-ring	O-ring	O-ring
*5	01 245 00	01 245 00	1	Pakning	Seal	Dichtung
*6	01 628 00	01 628 00	1	Nutring	Ring	Ring
*7	01 630 00	01 630 00	1	Støttering	Back-up ring	Stützring
8	02 046 00	02 046 00	1	Fjeder	Spring	Feder
9	02 047 00	02 047 00	1	Fjeder	Spring	Feder
10	02 068 00	02 068 00	2	Fjeder	Spring	Feder
*11	02 164 00	02 164 00	1	Kugle Ø5	Ball, Ø5	Kugel, Ø5
12	02 220 00	02 220 00	1	Låsering	Locking ring	Schliessring
*13	02 292 00	02 292 00	2	Kugle Ø6.5	Ball, Ø6.5	Kuegl, Ø6.5
14	02 425 00	02 425 00	1	Fitting	Fitting	Fitting
15	02 483 00	02 483 00	1	Prop	Plug	Pfropfen
16	02 503 00	02 503 00	1	Overtryksventil	Pressure control valve	Überdruckventil
*17	02 511 00	02 511 00	1	Filter	Filter	Filter
18	02 584 00	02 584 00	1	Prop	Plug	Pfropfen
19	02 753 00	02 753 00	1	Fjeder	Spring	Feder
20	02 931 00	02 931 00	1	Seegerring	Circlip	Seegerring
21	44 015 00	44 015 00	1	Lyddæmpermateriale	Sound absorber	Schalldämpfer
22	90 253 00	90 253 00	1	Udløserdæksel	Release cover	Deckel für Auslöser
23	90 254 00	90 254 00	1	Stempel f. udlø.ventil	Piston for release valve	Kolben für Auslöser
24	90 255 10	90 255 10	1	Udløsertap	Release pin	Auslöserzapfen
*25	90 695 00	90 695 00	1	Ventilindsats 1/8"RG	Valve core	Ventileinsatz
26	90 704 00	90 704 00	1	Afstandsbøsning	Distance sleeve	Abstandsbuchse
27	90 707 12	90 707 12	1	Pakboks	Packing box	Stopfbuchse
28	90 728 42	90 728 42	1	Luftmotor	Air machine	Luft Motor
29	90 729 00	90 729 00	1	Pumpeblok alt	Pump block	Pumpenblock
30	90 814 00	90 814 00	1	Lyddæmpersvøb	Sound absorber	Schalldämpfer
*31	91 128 00	91 128 00	2	Ventilindsats 1/4"RG	Valve catridge	Ventileinsatz
*	09 074 00	09 074 00		Pakningssæt	Repair kit	Dichtungssatz

	25-2	50-2		(DK)	(GB)	(DE)
Pos.	Art. No.	Art. No.	Pcs.	Benævnelse	Description	Bezeichnung
	90 728 42	90 728 42		Luftmotor, komplet	Air motor, complete	Luftmotor, komplett
1	02 347 00	02 347 00	1	Skruer	Screw	Schraube
2	90 267 03	90 267 03	1	Støtteskive	Back-up ring	Stützscheibe
3	90 267 12	90 267 12	1	Pumpestempel	Pump piston	Pumpkolben
4	90 268 00	90 268 00	1	Luftstempel, kpl.	Air piston, cpl.	Luftkolben, kpl.
5	90 709 04	90 709 04	1	Luftcylinder, kpl.	Air cylinder, cpl.	Luftzylinder, kpl.

DK: De med \* mærkede dele leveres i komplet pakningssæt. Anvend altid originale reservedele. Angiv venligst altid model og reservedelsnummer. Alle hoveddele kan ikke forventes leveret efter produktionsophør af model.

GB: \* indicate parts included in repair set. Please always state model and part number. Do always apply original spare parts. All major parts may not be provided as spare parts after discontinuation of production of a model.

DE: Die mit \* markierten Teile sind im Dichtungssatz enthalten. Bitte immer Modell und Ersatzteilnummer auf Ihren Bestellungen angeben. Immer nur Originalteile verwenden. Lieferung von allen Hauptteilen als Ersatzteile kann nach Produktions-Einstellung eines Modelles nicht erwartet werden.

25-2

Pos.	Art. No.	Pcs.	(DK) Benævnelse	(GB) Description	(DE) Bezeichnung
	<b>90 745 00</b>		<b>Cylinder, komplet</b>	<b>Cylinder, complete</b>	<b>Zylinder, komplett</b>
*1	01 031 00	1	O-ring	O-ring	O-ring
*2	01 055 00	1	O-ring	O-ring	O-ring
*3	01 080 00	1	O-ring	O-ring	O-ring
*4	01 081 00	1	O-ring	O-ring	O-ring
*5	01 152 00	1	Støttering	Back-up ring	Stützring
*6	01 153 00	1	Støttering	Back-up ring	Stützring
*7	01 282 00	1	Afstryger	Scraper ring	Abstreifer
*8	01 287 00	1	Afstryger	Scraper ring	Abstreifer
9	02 493 00	1	Fitting	Fitting	Fitting
10	02 584 00	1	Prop	Plug	Propfen
11	02 859 00	1	Sænke-bremseventil	Brake valve	Bremseventil
12	90 733 00	1	Stempel	Piston	Kolben
13	90 734 00	1	Stempel	Piston	Kolben
14	90 737 00	1	Sadel	Saddle	Sattel
15	90 746 00	1	Cylinderbund	Cylinder bottom	Zylinderboden
16	90 747 00	1	Mellemcylinder	Middle cylinder	Mittelzylinder
17	90 748 00	1	Stempelstok	Piston rod	Kolbenstange
18	90 749 00	1	Hovedcylinder	Main cylinder	Hauptzylinder
*	09 033 00		Pakningssæt	Repair kit	Dichtungssatz

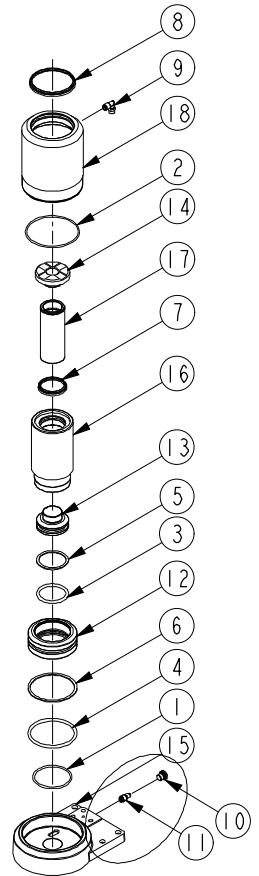
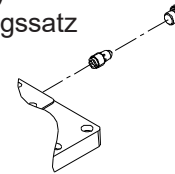

## 90 740 00

50-2

Pos.	Art. No.	Pcs.	(DK) Benævnelse	(GB) Description	(DE) Bezeichnung
	<b>90 740 00</b>		<b>Cylinder, komplet</b>	<b>Cylinder, complete</b>	<b>Zylinder, komplett</b>
*1	01 022 00	1	O-ring	O-ring	O-ring
*2	01 031 00	1	O-ring	O-ring	O-ring
*3	01 042 00	1	O-ring	O-ring	O-ring
*4	01 081 00	1	O-ring	O-ring	O-ring
*5	01 082 00	1	O-ring	O-ring	O-ring
*6	01 153 00	1	Støttering	Back-up ring	Stützring
*7	01 154 00	1	Støttering	Back-up ring	Stützring
*8	01 278 00	1	Afstryger	Scraper ring	Abstreifer
*9	01 287 00	1	Afstryger	Scraper ring	Abstreifer
10	02 493 00	1	Fitting	Fitting	Fitting
11	02 584 00	1	Prop	Plug	Propfen
12	90 731 00	1	Cylinderbund	Cylinder bottom	Zylinderboden
13	90 732 00	1	Stempel	Piston	Kolben
14	90 733 00	1	Stempel	Piston	Kolben
15	90 737 00	1	Sadel	Saddle	Sattel
16	90 741 00	1	Stempelstok	Piston rod	Kolbenstange
17	90 742 00	1	Mellemcylinder	Middle cylinder	Mittelzylinder
18	90 743 00	1	Hovedcylinder	Main cylinder	Hauptzylinder
*	09 034 00		Pakningssæt	Repair kit	Dichtungssatz

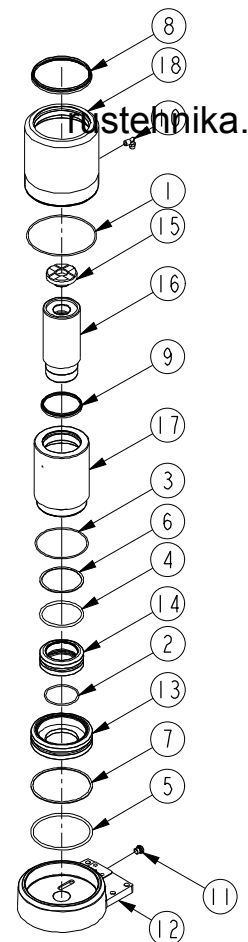

DK: De med \* mærkede dele leveres i komplet pakningssæt. Anvend altid originale reservedele. Angiv venligst altid model og reservedelsnummer. Alle hoveddele kan ikke forventes leveret efter produktionsophør af model.

GB: \* indicate parts included in repair set. Please always state model and part number. Do always apply original spare parts. All major parts may not be provided as spare parts after discontinuation of production of a model.

DE: Die mit \* markierten Teile sind im Dichtungssatz enthalten. Bitte immer Modell und Ersatzteilnummer auf Ihren Bestellungen angeben. Immer nur Originalteile verwenden. Lieferung von allen Hauptteilen als Ersatzteile kann nach Produktions-Einstellung eines Modelles nicht erwartet werden.

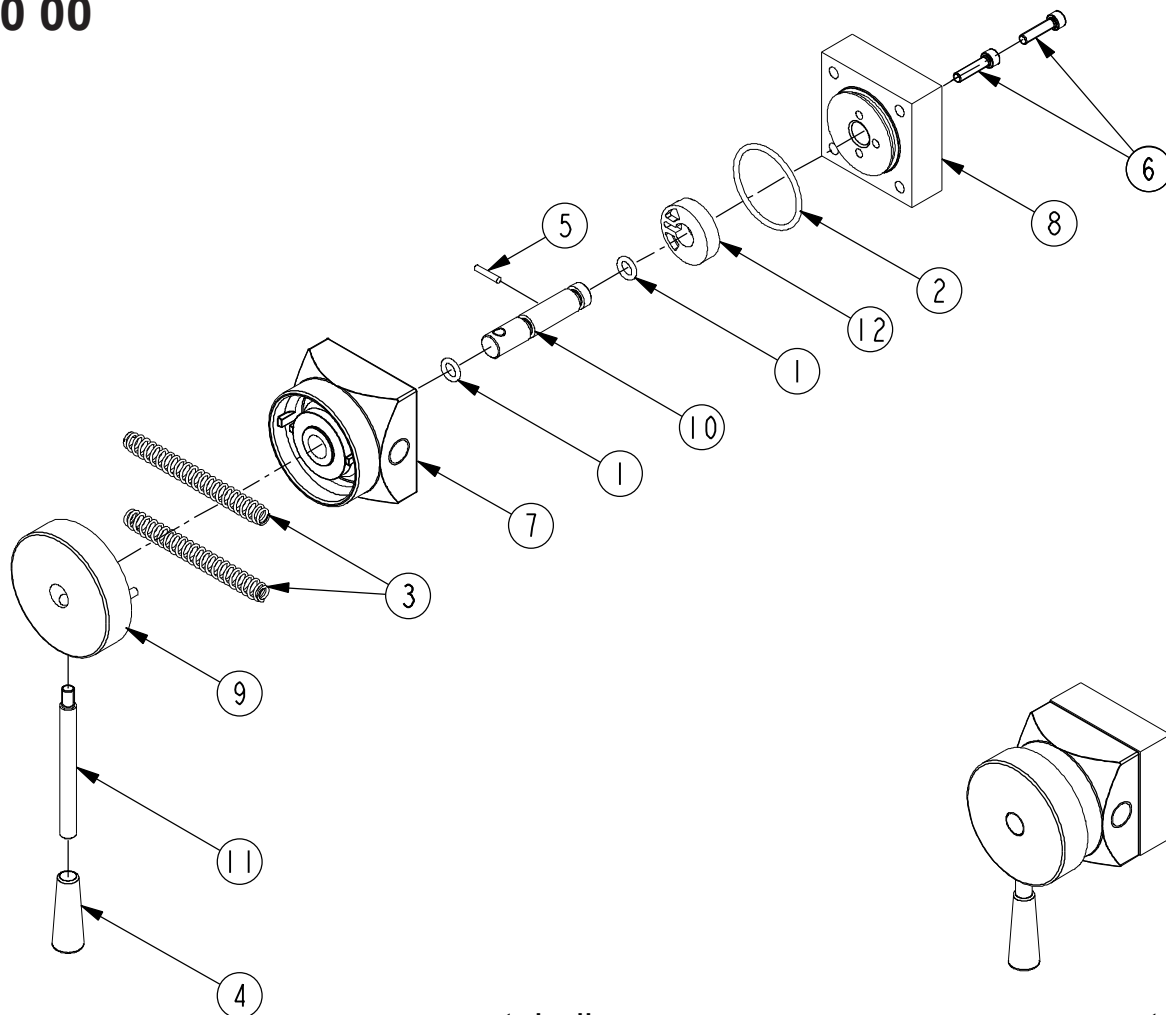

Pos.	25-2 Art. No.	50-2 Art. No.	(DK) Pcs. Benævneelse	(GB) Description	(DE) Bezeichnung
	42 000 00	42 000 00		Betjeningsventil, kpl	Ventil, kpl
1	01 057 00	01 057 00	2	O-ring	O-ring
2	01 058 00	01 058 00	1	O-ring	O-ring
3	02 064 00	02 064 00	2	Fjeder	Feder
4	02 086 00	02 086 00	1	Prop	Pfropfen
5	02 277 00	02 277 00	1	Kærvstift	Stift
6	02 302 00	02 302 00	2	Skrue	Schraube
7	42 001 00	42 001 00	1	Ventiloverpart	Ventiloberteil
8	42 002 00	42 002 00	1	Ventilunderpart	Ventilunterteil
9	42 003 02	42 003 02	1	Drejehåndtag	Drehscheibe
10	42 004 00	42 004 00	1	Ventilspindel	Ventilspindel
11	42 005 00	42 005 00	1	Håndtagsaksel	Achse für Drehscheibe
12	42 006 00	42 006 00	1	Ventilglider	Ventilschieber



44 001 00

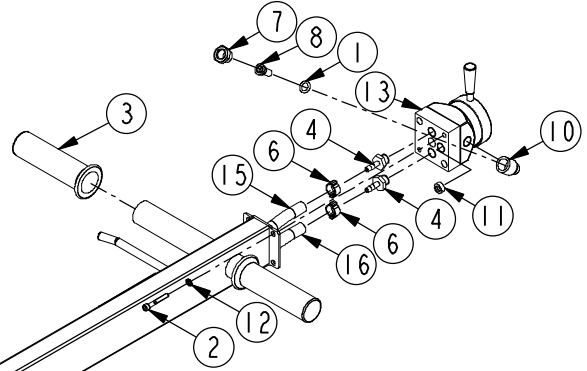
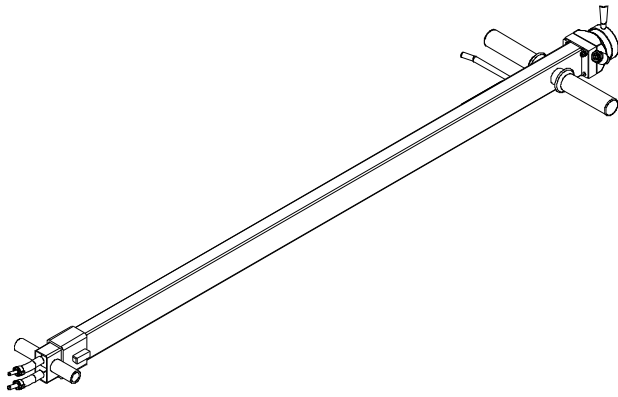

rustehnika.ru

rustehnika.ru

rustehnika.ru

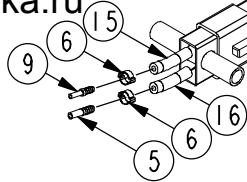

Pos.	25-2 Art. No.	50-2 Art. No.	Pcs.	(DK) Benævnelse	(GB) Description	(DE) Bezeichnung
	44 001 00	44 001 00		Håndtag, komplet	Handle, complete	Hebel, komplett
1	01 000 00	01 000 00	1	O-ring	O-ring	O-ring
2	02 004 61	02 004 61	2	Skrue	Screw	Schraube
3	02 390 00	02 390 00	2	Håndtag	Handle	Hebel
4	02 414 00	02 414 00	2	Slangestuds	Hose union	Schlauchstuz
5	02 418 00	02 418 00	1	Slangestuds	Hose union	Schlauchstuz
6	02 421 00	02 421 00	4	Slangeklemme	Hose clamp	Schlauchklemme
7	02 506 00	02 506 00	1	Fitting	Fitting	Fittings
8	02 511 00	02 511 00	1	Filter	Filter	Filter
9	02 514 00	02 514 00	1	Slangestuds	Hose union	Schlauchstuz
10	02 515 00	02 515 00	1	Fitting	Fitting	Fitting
11	02 560 00	02 560 00	1	Lyddæmper	Silencer	Dämpfer
12	02 681 00	02 681 00	2	Skive	Washer	Scheibe
13	42 000 00	42 000 00	1	Betjeningsventil, kpl.	Control valve, cpl.	Bedienfeld
14	44 002 00	44 002 00	1	Håndtag	Handle	Hebel
15	90 881 54	90 881 54	1	Slange	Hose	Schlauch
16	90 881 59	90 881 59	1	Slange	Hose	Schlauch

rustehnika.ru

rustehnika.ru

rustehnika.ru

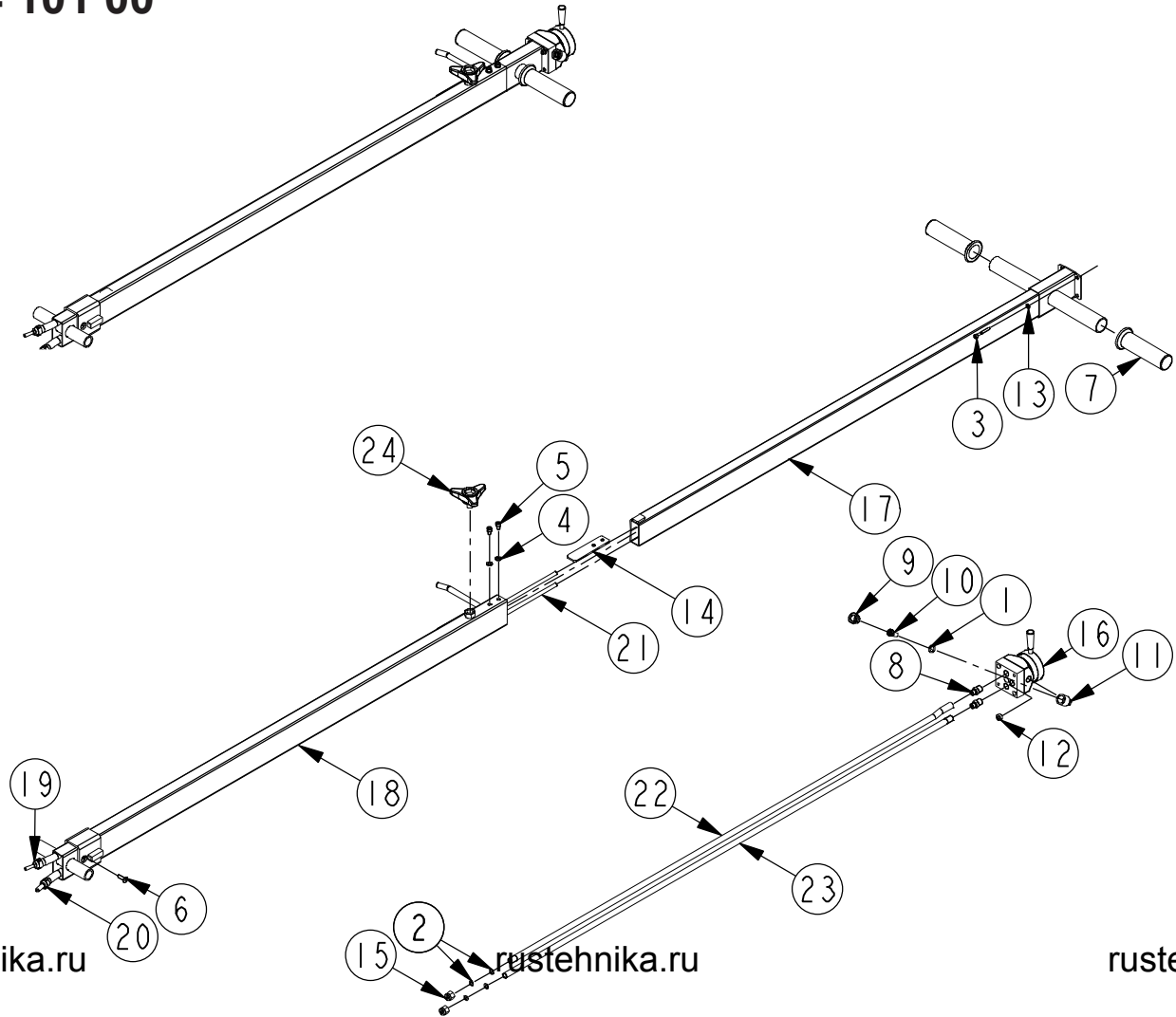

	25-2	50-2		(DK)	(GB)	(DE)
Pos.	Art. No.	Art. No.	Pcs.	Benævnelse	Description	Bezeichnung
	44 101 00	44 101 00		Teleskophåndtag, kpl.	Telescopic handle, cpl.	Teleskophebel, kpl.
1	01 000 00	01 000 00	1	O-ring	O-ring	O-ring
2	01 056 00	01 056 00	4	O-ring	O-ring	O-ring
3	02 004 61	02 004 61	2	Skrue	Screw	Schraube
4	02 111 00	02 111 00	2	Skive	Washer	Scheibe
5	02 307 00	02 307 00	2	Skrue	Screw	Schraube
6	02 315 00	02 315 00	1	Skrue	Screw	Schraube
7	02 390 00	02 390 00	2	Håndtag	Handle	Hebel
8	02 423 00	02 423 00	2	Fitting	Fitting	Fittings
9	02 506 00	02 506 00	1	Fitting	Fitting	Fittings
10	02 511 00	02 511 00	1	Filter	Filter	Filter
11	02 515 00	02 515 00	1	Fitting	Fitting	Fittings
12	02 560 00	02 560 00	1	Lyddæmper	Silencer	Dæmpfer
13	02 681 00	02 681 00	2	Skive	Washer	Scheibe
14	40 014 00	40 014 00	1	Låselaske	Locking hinged joint	Klemmelaske
15	40 021 00	40 021 00	2	Omløbermøtrik	Union nut	Überwurfmutter
16	42 000 00	42 000 00	1	Betjeningsventil, kpl.	Control valve	Steuerventil
17	44 102 00	44 102 00	1	Udtrækshåndtag	Extension handle	Ausziehbarer Hebel
18	44 103 00	44 103 00	1	T-håndtag	Fixed handle	Hebel, fast
19	44 104 00	44 104 00	1	Slange	Hose	Schlauch
20	44 105 00	44 105 00	1	Slange	Hose	Schlauch
21	44 106 00	44 106 00	1	Teleskoprør	Telescopic pipe	Teleskoprohr
22	44 107 00	44 107 00	1	Teleskoprør	Telescopic pipe	Teleskoprohr
23	44 108 00	44 108 00	1	Teleskoprør	Telescopic pipe	Teleskoprohr
24	44 109 00	44 109 00	1	Låsehåndtag	Locking hand grip	Klemmeschraube

Ⓚ **HYDRAULIK DIAGRAM**

Ⓜ **HYDRAULIC CHART**

Ⓓ **HYDRAULISCHES DIAGRAMM**

### 25-2

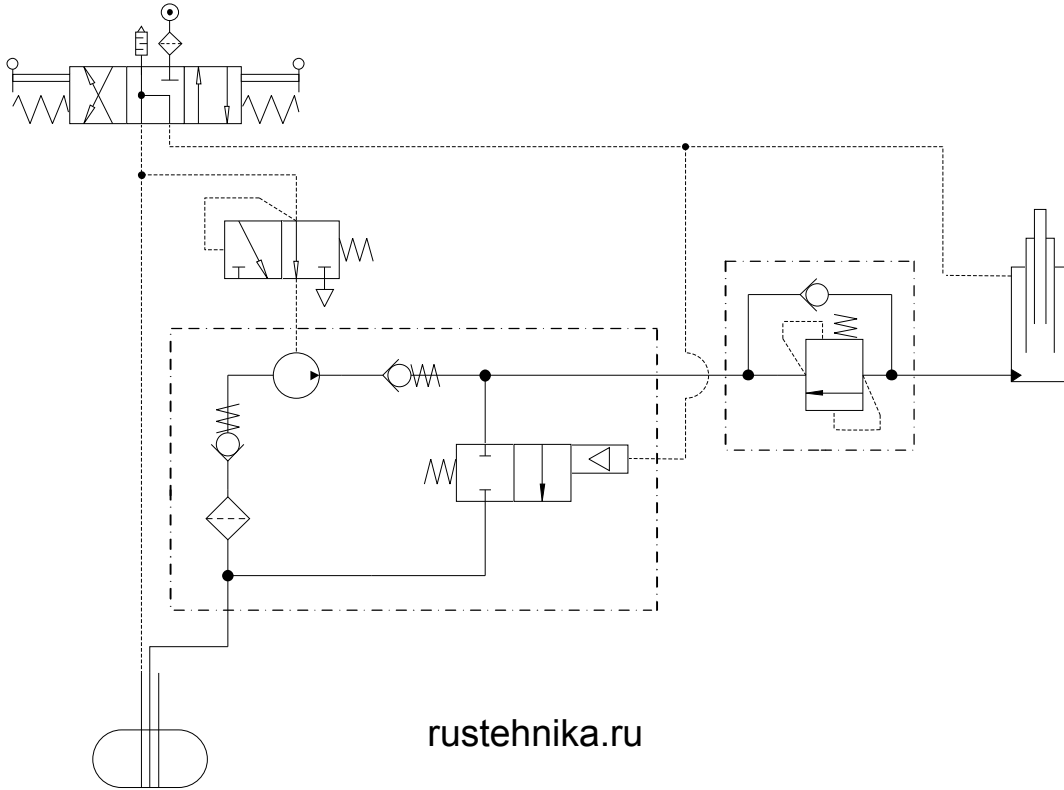

### 50-2

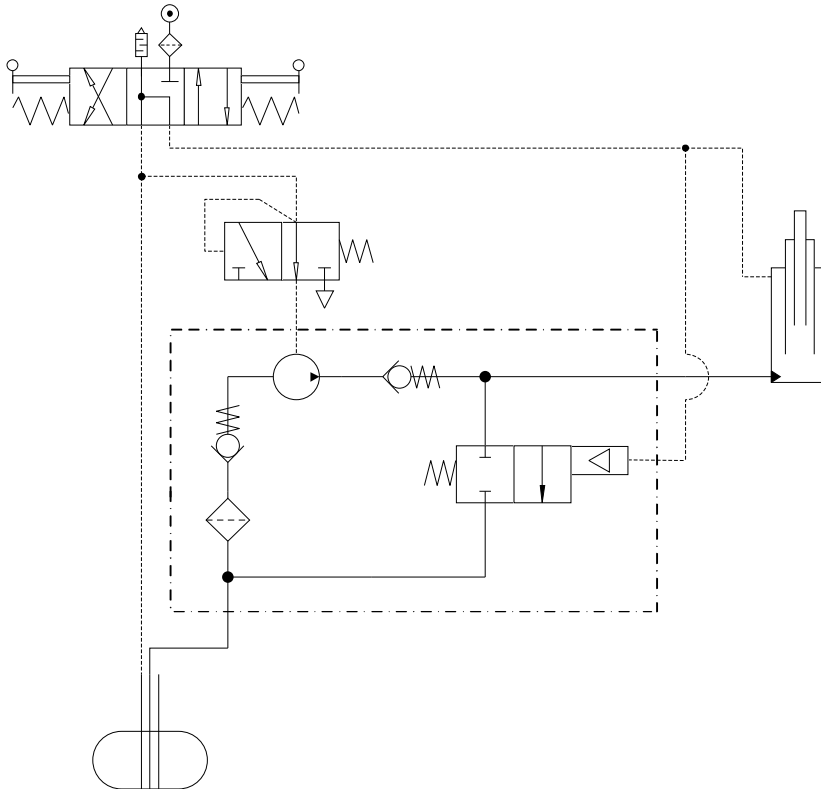

(DK) **TILBEHØR**  
 (GB) **ACCESSORIES**  
 (DE) **ZUBEHÖR**

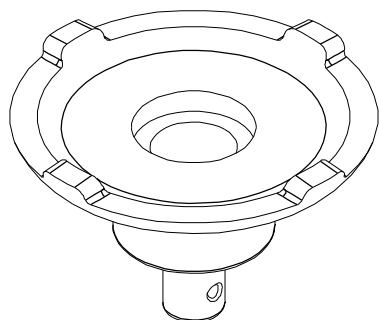

Art. No.	Pcs.	(DK) Benævnelse	(GB) Description	(DE) Bezeichnung
44 021 00	1	Sadel D 145mm	Saddle D 145mm	Sattel D 145mm



Art. No.	Pcs.	(DK) Benævnelse	(GB) Description	(DE) Bezeichnung
63 231 00	1	V-sadel	V-saddle	V-sattel



Art. No.	Pcs.	(DK) Benævnelse	(GB) Description	(DE) Bezeichnung
44 020 00	1	Forlænger 250 mm	Extension 250 mm	Verlängerung 250 mm

- (DK) Specialforlængeren må **ikke** anvendes sammen med andre forlængere!!  
 (GB) Special extension may **not** be used with other extensions!!  
 (DE) Special Verlängerungen darf **nicht** mit anderen Verlängerungen benutzt werden!!

EU Overensstemmelseserklæring  
 EC Declaration of Conformity for Machinery  
 EG Konformitätserklärung  
 Declaration CE de conformité  
 pour les composants

EU Överensstämmelseforsäkran  
 Vaatimustenmukaisuuvakuutus  
 EU verklaring van overeenstemming  
 EU declaración de conformidad  
 sobre maquinaria

## Directive 2006/42/EC

**(DK)** Lufthydraulisk donkraft,  
**(NO)** **25-2, 25-2TH, 50-2, 50-2TH**  
 er i overensstemmelse med Maskindirektivets bestem-  
 melser (Direktiv 2006/42/EC og EN1494).  
 Claus A. Christensen, Fanøvej 6, DK-8800 er bemyndi-  
 get til at udarbejde det tekniske dossier.

**(SE)** Lufthydraulisk domkraft  
**25-2, 25-2TH, 50-2, 50-2TH**  
 Överensstämmer med Maskindirektivets bestämmelser  
 (Direktiv 2006/42/EC och EN1494).  
 Claus A. Christensen, Fanøvej 6, DK-8800 är behörig  
 att ställa samman den tekniska dokumentationen.

**(GB)** Air-hydraulic Jack,  
**25-2, 25-2TH, 50-2, 50-2TH**  
 are in conformity with the provisions of the Machinery  
 Directive (Directive 2006/42/EC and EN1494)  
 Mr. Claus A. Christensen, Fanøvej 6, DK-8800 is au-  
 thorized to compile the technical file.

**(FI)** Ilmahydraulitunkki,  
**25-2, 25-2TH, 50-2, 50-2TH**  
 vastaa Konedirektiivin (direktiivi 2006/42/EC ja  
 EN1494).  
 Claus A. Christensen, Fanøvej 6, DK-8800 on valtu-  
 utettu kokoamaan teknisen tiedoston.

**(DE)** Lufthydraulische Heber,  
**25-2, 25-2TH, 50-2, 50-2TH**  
 konform sind mit den einschlägigen Bestimmungen der  
 EG-Maschinenrichtlinie 2006/42/EC und EN1494.  
 Herr Claus A. Christensen, Fanøvej 6, DK-8800 ist  
 berechtigt, die technischen Unterlagen zusammenzus-  
 tellen.

**(NL)** Lucht-hydraulische krik,  
**25-2, 25-2TH, 50-2, 50-2TH**  
 in overeenstemming zijn met de bepalingen van de  
 Richtlijn Machines (richtlijn 2006/42/EC en EN1494).  
 Claus A. Christensen, Fanøvej 6, DK-8800 gemachtigd  
 is om het technisch dossier samen te stellen.

**(FR)** Cric hydropneumatique,  
**25-2, 25-2TH, 50-2, 50-2TH**  
 sont conformes aux dispositions de la Directive Ma-  
 chine 2006/42/EC et EN1494  
 Claus A. Christensen, Fanøvej 6, DK-8800 est autori-  
 sée à constituer le dossier technique.

**(ES)** Gato hidráulico,  
**25-2, 25-2TH, 50-2, 50-2TH**  
 son conforme con las directrices sobre maquinaria  
 (Directiva 2006/42/EC y EN1494).  
 Claus A. Christensen, Fanøvej 6, DK-8800 está facul-  
 tado para elaborar el expediente técnico.



**AC Hydraulic A/S**  
 Fanøvej 6  
 DK-8800 Viborg - Danmark  
 Tel.: +45 8662 2166  
 Fax: +45 8662 2988  
 E-mail: ac@ac-hydraulic.dk  
 www.ac-hydraulic.com

  
 Claus A. Christensen  
 General Manager  
 Viborg 01.01.15

