

RUSTEHNKA

RUSTEHNKA

RUSTEHNKA



Operating Instructions for hose reel



RUSTEHNKA

RUSTEHNKA

RUSTEHNKA

GB

USA

87836 A402 GB/USA

RUSTEHNKA

RUSTEHNKA

RUSTEHNKA

Operating Instructions for hose reel

(all models)

Description

Spring-operated hose reel with hose for delivering or drawing off various substances. It can be equipped with a flow meter, lubrication pistols or various pneumatic tools. It can be installed in permanent supply networks or used to equip stationary or mobile plants.

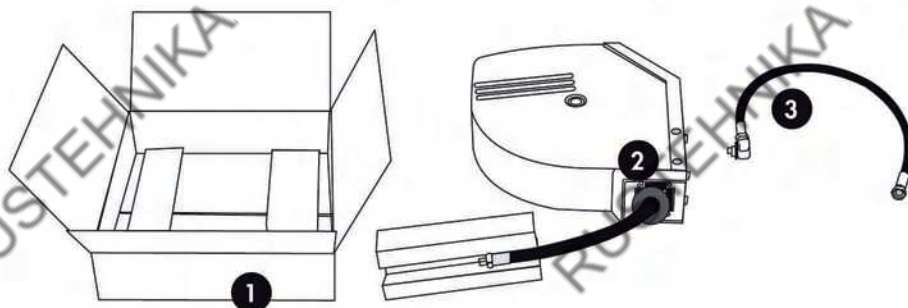

Contents of the box

The box **1** contains the assembled hose reel with the pressure hose **2** and connecting hose **3**.

Connecting hose and connecting swivel **3** for the encased model are situated within the hose reel casing.

Fastening material such as screws, dowels etc. are to be obtained by the purchaser in the version required.

Safety notices

1. Read these instructions carefully before you install the hose reel at the intended place of use.
2. The PRESSOL hose reel requires no maintenance. Do not change any parts yourself and do not open the equipment unless you are explicitly told to do so in these instructions for use.
3. On account of its weight and to ensure your own safety, the installation of the hose reel should be carried out by two people.
4. If the hose reel is to be mounted on a ceiling or at a high position on a wall, you are in danger of losing your balance and seriously injuring yourself. In such cases, please use a ladder.
5. If the hose will be bent by more than 30° in relation to the perpendicular of the hose reel when it is being pulled out, a swivel bracket must be used in order to protect the hose.
6. Do not bend the hose, do not place any heavy objects on it and do not drive over it.
7. If you notice any damage to the hose or the hose reel, contact your dealer. Do not attempt to repair the damage yourself.
8. The return spring in the hose drum is under high initial tension. Do not open the drum under any circumstances. You could be seriously injured by the spring if it shot out.
9. Do not let the hose rewind in an uncontrolled manner. The swirling end of the hose with the attached pistol and lance could seriously injure anybody who might be standing in the way.
10. Take care that the outer surface of the hose does not remain in contact with aggressive liquids for longer periods of time.
11. In the case of hose reels without a casing, keep your limbs or loose-fitting clothing away from the drum or its frame. Limbs and clothing could be caught up in the rotating drum and thus cause injuries.

1. Preparations before installing

1.1 Determining the place of installation and the materials required

1. The safe and trouble-free operation of the PRESSOL hose reel is directly dependent upon the choice of a suitable place of installation.
2. The hose reel can weigh up to 40 kg when it is assembled, filled with the substance to be pumped and in operation. The additional strain which results when the hose is being pulled out of the casing must also be taken into consideration. When installing, make sure that the surface it is to be mounted to is **stable and capable of bearing this load** and preferably made of concrete or firm masonry. Thin wooden flooring, plasterboard walls or suspended ceilings are not suitable.
3. The surface must be level and the drillholes for the fastening screws must correspond exactly with the holes in the supporting plate/mounting bracket. If this is not the case, it may lead to tension and perfect running cannot be guaranteed.
4. Select screws and dowels of sufficient size for fastening purposes.
5. You will require the following tools for the installation:
 1 x 5 mm socket-screw wrench (Allen key),
 1 x 8 mm open-ended or ring spanner,
 2 x 17 mm open-ended or ring spanner,
 1 x 22 mm open-ended spanner,
 1 x 32 mm open-ended spanner,
6. Before you begin with the installation, make sure that all the materials and tools you require are close at hand.
7. If the hose reel is to be **mounted to the ceiling** you will also require an **angle bracket** with which the upper, sloping edge of the mounting bracket can be secured. In this case, the step 1.4 "Separating the supporting plate and the mounting bracket" does not apply.

1.2 Removing the casing (only for models with a casing)

Tools required: 8 mm ring- or open-ended spanner.
 Take care that the hose has been completely rewound.

- 1 Unscrew both of the casing screws (8 mm spanner).
- 2 Open up the casing in the direction of the hose.
- 3 Remove the casing by pulling it upwards.
- 4 Put the casing carefully aside.

Take care! The edges of the casing which are now exposed are sharp and there is a risk of injury!

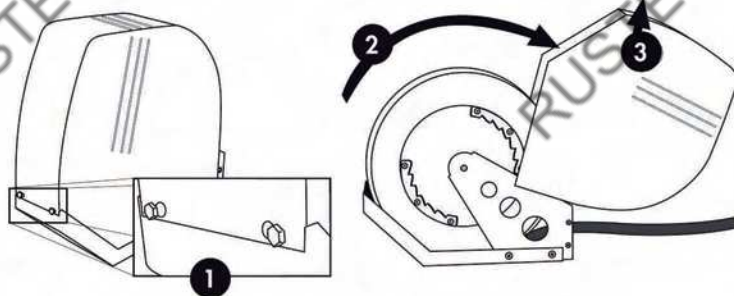

1.3 Removing the mounting bracket/ supporting plate (all models)

Tools required: 5 mm socket screw wrench.

- 1 Place the hose reel on its drum and wedge the hose (1) under the drum in such a way that the former is in a **firm** standing position.
- 2 Unscrew the countersunk socket-head screws (2) on the left-hand and right-hand side of the mounting bracket.
- 3 Remove the mounting bracket by pulling it forwards. Put it aside.
- 4 Put the drum aside.

Take care!

Do not let the drum fall over when you are working.

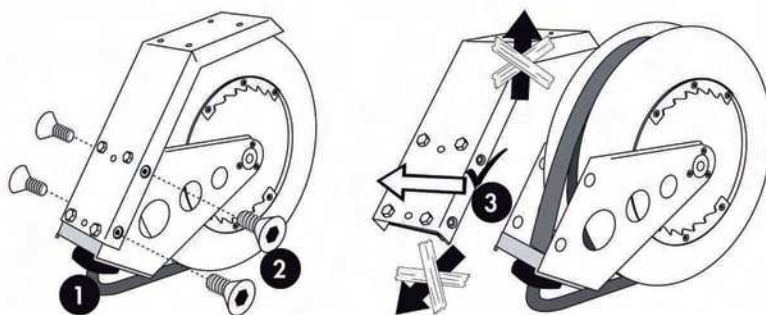

1.4 Separating the supporting plate **S** and the mounting bracket **K** (only for models with a mounting bracket, not for ceiling mounting)

Tools required: Two 17 mm ring or open-ended spanners.

The supporting plate is the part with which the hose reel is held in place. It is to be used beforehand as a template for marking the position of the drillholes.

Unscrew the nuts from the bolts and remove the supporting plate from the mounting bracket.

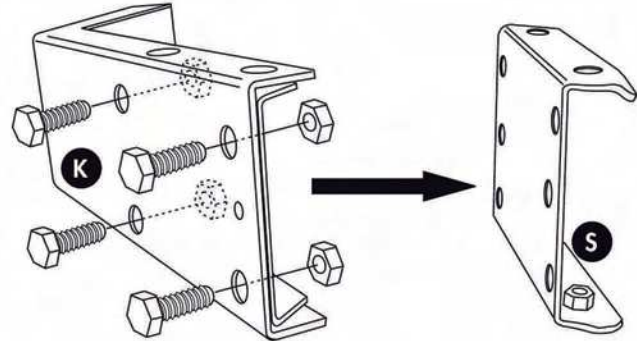

2. Installation

The place of installation must comply with the requirements stated above!

Always use the supporting plate as a template regardless of whether you want to use the hose reel with or without a casing, whether you want to mount it to the floor, wall or ceiling or use it together with a swivel bracket (wall mounting).

D = swivel bracket

B = angle bracket for the ceiling

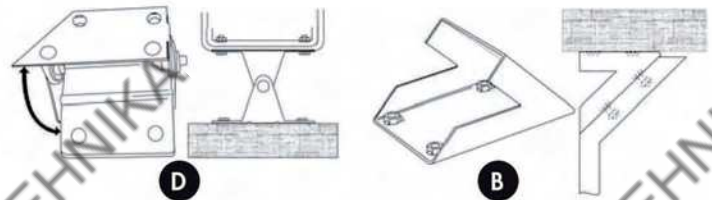

2.1 Installation positions (examples)

- 1** floor
- 2** wall
- 3** wall with swivel bracket (D)
- 4** ceiling

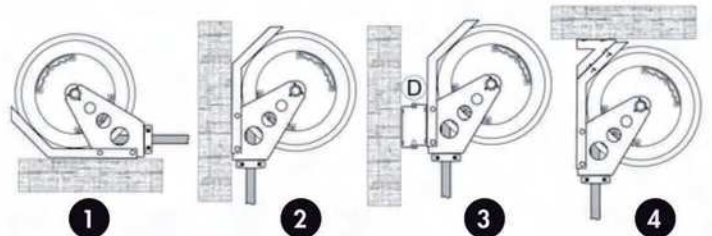

2.2 Drilling the holes for the fastening screws

Please note! The screws and the dowels you require depend upon the masonry which the hose reel is to be attached to. No exact specifications can be made here. In the case of floors or concrete walls, 10x80 mm screws with the corresponding dowels are usually sufficient.

1. Position the supporting plate on the surface where the hose reel is to be mounted in such a way that the slanting, open ends of the U-shaped plate are at least 50 cm away from the next wall (floor installation). In the event of a wall installation, the plate must be at least 50 cm away from the ceiling and 60 cm away from the floor. Adjust the template using the spirit level.
2. Mark the position of the four holes for the dowels.
3. Drill the holes for the dowels in accordance with the masonry and the screws which are going to be used.
4. Insert the dowels and make sure that they fit well.

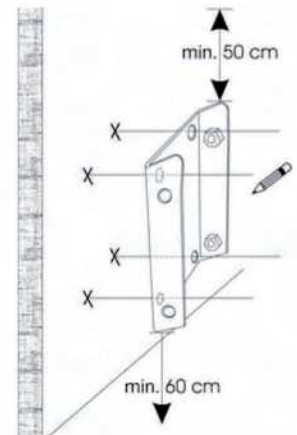

2.3 Fastening the angle bracket and the swivel bracket at the place of installation

If the hose reel is to be **mounted to the wall using the swivel bracket**, fasten the swivel bracket to a load-bearing surface as follows: the longitudinally crimped plate must lie on the surface which the reel is to be mounted to and the conically shaped pivot must be at the bottom.

If the hose reel is to be **mounted to the ceiling**, fasten the angle bracket to the ceiling.

2.4 Fastening the supporting plate/mounting bracket (floor/wall installation)

Reels without mounting bracket/casing ①

Fasten the supporting plate by screwing the four screws into the dowels. The slanting, crimped edges of the plate must be facing upwards (wall installation), in the opposite direction from which the hose leaves the reel (floor installation).

Reels with mounting bracket/casing ②

1. Insert the supporting plate into the mounting bracket in such a way that the two round bosses interlock with the two middle holes in the supporting bracket and the slanting, crimped edges of the supporting plate are pointing towards the angled part of the mounting bracket.
2. The supporting plate and the mounting bracket can then be fastened by screwing the four screws into the dowels.

Reels without mounting bracket/casing using the swivel mounting ③

After fastening the swivel bracket safely to a load-bearing surface as described in section 2.3, fasten the supporting plate to the carrier plate of the swivel bracket by means of four M10x20 bolts and nuts.

Reels with mounting bracket/casing using the swivel mounting ④

1. Insert the supporting plate into the mounting bracket in such a way that the two round bosses interlock with the two middle holes in the supporting bracket and the slanting, crimped edges of the supporting plate are pointing towards the angled part of the mounting bracket.
2. After fastening the swivel bracket safely to a load-bearing surface as described in section 2.3, fasten the supporting plate to the carrier plate of the swivel bracket by means of four M10x20 bolts and nuts.

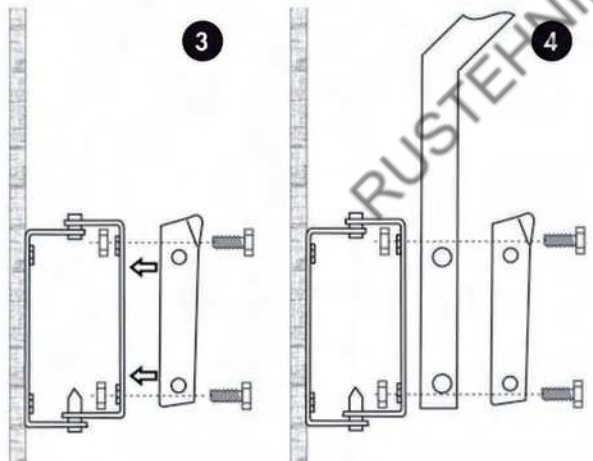
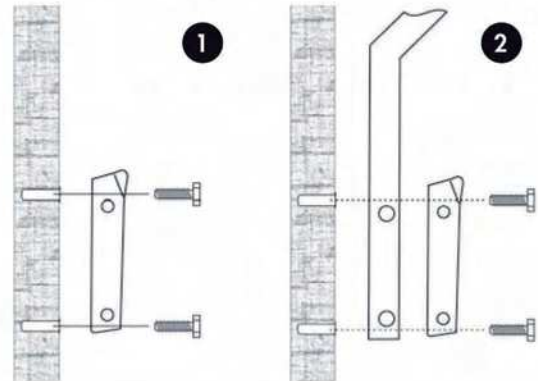

2.5 Fastening the mounting bracket (ceiling installation)

If the hose reel is to be fastened to the ceiling, an angle bracket and a mounting bracket are always needed. The swivel bracket is not intended for an installation on the ceiling.

1. Insert the supporting plate into the mounting bracket in such a way that the two round bosses interlock with the two middle holes in the supporting bracket and the slanting, crimped edges of the supporting plate are pointing towards the angled part of the mounting bracket.
2. After fastening the angle bracket safely to a load-bearing surface as described in section 2.3, fasten the supporting plate and the mounting bracket with four M10x20 bolts and nuts to the angle bracket.

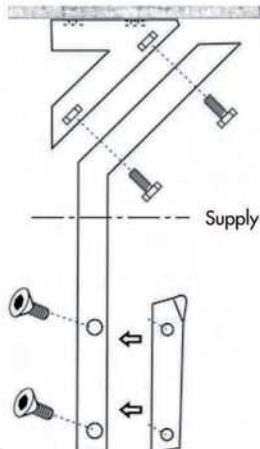

2.6 Suspending the hose drum in its mountings and securing it

Please pay attention to the safety notices!

1. When you insert the drum, the folded over edges of the drum frame must rest on the slanting, crimped edges of the supporting plate. If you insert the drum into a mounting bracket, the sides of the drum frame must be guided between the sides of the mounting bracket and the supporting plate.
2. Adjust the drum so that the drillholes in the supporting plate and those in the drum frame correspond exactly with one another.
3. Fasten the drum to its support by means of the four hexagonal socket-head screws.

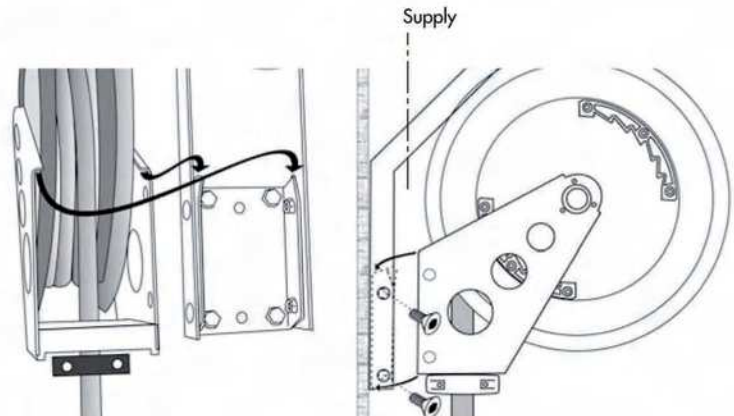

2.7 Attaching the casing

Please pay attention to the safety notices!

1. Insert the tongue of the casing into the hose exit. This functions as a retainer and pivot.
2. Pivot the casing on this axis in the direction of the mounting bracket until it rests completely in the mounting bracket. Guide the sides of the casing between the mounting bracket and the drum frame (take care that you do not cut yourself!).
3. Fasten the casing to the mounting bracket by means of the two screws.

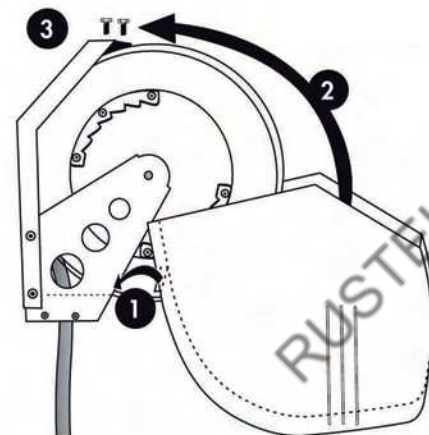

2.8 Attaching the connecting hose

Take care! The threads and the spacing washers on the drum, the swivel joint and the connecting hose must be free of dust and dirt!

1. Unscrew the connecting hose from the swivel joint.
2. Remove the dust-proof cover from the drum's internal screw thread.
3. Screw the swivel joint into the drum's screw thread and tighten the nut securely.
4. Screw the connecting hose to the swivel joint and tighten the nut securely.
5. Connect up the other end of the connecting hose to the supply source. Tighten the nut securely. **Please pay attention to any instructions contained in the documents provided with the supply source.**

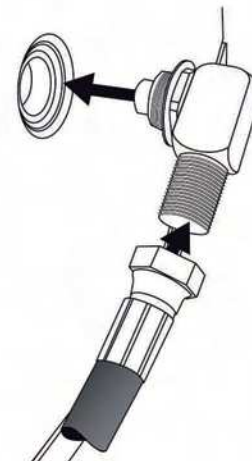

2.9 Attaching a pistol

Before attaching a pistol and any other accessories (lance or the like), please refer to the documents provided with them.

2.10 Adjusting the hose stopper

Your hose reel is equipped with a hose stopper.

1. Pull out the length of hose you require in order to position the stopper. Let the hose engage.
2. Loosen the socket-head screws (indicated by the arrows in the illustration) with the 5 mm socket-screw wrench (Allen key) until the two halves of the hose stopper can be pushed backwards and forwards on the hose.
3. Push the hose stopper to the position on the hose where you would like it to be and tighten the screws very securely again.

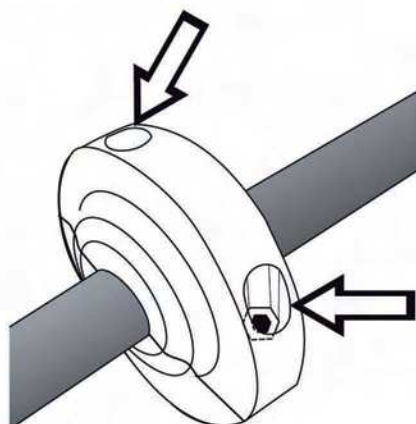

3. Hose reel with concealed swivel joint

In the case of the reel with concealed swivel joint, the installation steps are as follows:

1. Connect the connecting hose to the drum first (see section 2.8).
2. Then push the connecting hose through one of the oval holes in the mounting bracket.
3. Attach the casing (see section 2.7).

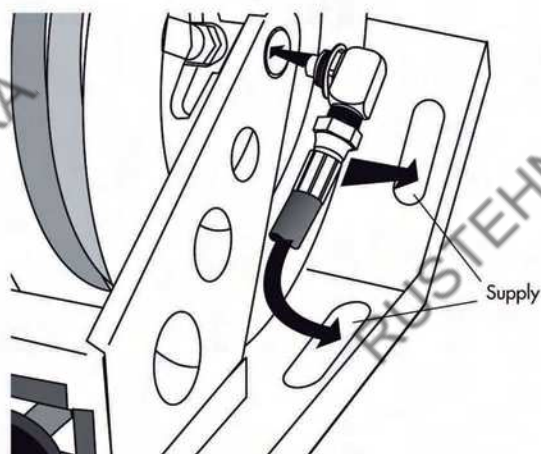

4. Operating

The hose reel is equipped with an automatic locking mechanism. Pull out the hose to the length you require. When you do so, you can hear a loud rasping sound. If you loosen your hold on the hose, the drum will slightly rewind (approx. a quarter of a revolution) and then engage.

If you want to rewind the hose onto the drum, pull the hose until you cannot hear the rasping sound for a short period. If you loosen your hold on the hose now, it will be retracted and wound onto the drum. Keep hold of the hose when it is being rewound and **do not let go!**

Technical specifications

hose reel type	swivel joint	weights		length	dimensions mm	
		from	to		breadth	height
open, wall/floor installation	–	16,8	19,5	472	152	498
open, ceiling installation	–	20,4	23,1	475	158	520
closed, wall/floor installation	inside	23,8	26,5	495	170	508
closed, wall/floor installation	outside	23,4	26,1	495	158	508
closed, ceiling installation	inside	23,2	25,9	495	170	520
closed, ceiling installation	outside	23,6	26,3	495	158	520

Temperature ranges

ambient temperature	temperature of substances
min. + 10 °C, max. + 60 °C	+ 10 °C - + 60 °C
	when drawing off oil + 10 °C - + 80 °C
	for hot water + 10 °C - + 130 °C

Connections

substance	type SAR	operating pressure	connecting hose	delivery hose possible lengths
oil	12-10/15 Ö	120 bar	1 m, DN 12, G 1/2"	10/15 m, DN 12, G 1/2"
grease	6-10/15 F	400 bar	1 m, DN 6, G 1/4"	10/15 m, DN 6, G 1/4"
diesel/fuel oil	16-8 D	60 bar	1 m, DN 20, G 3/4"	8 m, DN 16, G 3/4"
air/water	10-10/15 L	20 bar	1 m, DN 10, G 3/8"	10/15 m, DN 10, G 3/8"
cooling agent	12-10/15 K	120 bar	1 m, DN 12, G 1/2"	10/15 m, DN 12, G 1/2"
hot water	10-10/15 H	200 bar	1 m, DN 10, G 3/8"	10/15 m, DN 10, G 3/8"

Declaration of conformity

In accordance with the EEC directive 89/392/EWG governing machines, appendix II A, we declare that the equipment as supplied by us, confirms with the relevant directives.

Please do not use the hose reel until all requirements of the EEC directive 89/392/EWG governing machines, appendix II A, are fulfilled.

Equipment: Hose reel

PRESSOL Schmiergeräte GmbH

Type: SAR 12-10/15 Ö
SAR 6-10/15 F
SAR 16-8 D
SAR 10-10/15 L
SAR 12-10/15 K
SAR 10-10/15 H

05.02.2001

Dipl.-Ing. Rudolf Schlenker

Repairs/Service

PRESSOL Schmiergeräte GmbH

Tel. +49 911 32441-35 · Fax +49 911 32441-65 · export@pressol.com

PRESSOL