







443

4,0 t

CE







-  Sollevatore elettroidraulico a 4 colonne super-ribassato
-  **Electro-hydraulic low profile 4 post lift**
-  Elektrohydraulische 4-Säulen-Hebebühne mit niedriger Auffahrhoehe
-  Pont élévateur électro-hydraulique à 4 colonnes surbaissé
-  Elevador electro-hidráulico de 4 columnas súper-bajo



* Optional

Carter protezione centralina
Cover for control unit
 Abdeckung für Hydraulikaggregat
 Carter protection centrale hydraulique
 Cubierta protectora para la centralita

-  Alta velocità di sollevamento • Sicurezza idraulica contro il sovraccarico • Valvola regolazione discesa • Segnale acustico ultimo tratto di discesa • Sicurezza idraulica in caso di rottura tubi idraulici • Comandi uomo presente 24 V • Sgancio automatico delle sicurezze per la discesa
-  High lifting and descent speed • Overload safety valve • Descent control valve • "Buzzer" on last portion of descent • Pipe burst safety valve • 24 V, low tension dead man controls •
-  Hohe Hub-und Senkgeschwindigkeit • Überdruckventil als Überlastsicherung • Senksteuerventil • Akustisches Signal im letzten Teil der Senkbewegung • Rohrbruch-Sicherheitsventil • 24 V-Totmannschaltung • Automatische Entriegelung der Lastsicherungshebel vor dem Absenken
-  Grande vitesse de levage et descente • Vanne de surpression contre surcharges • Vanne de réglage descente • Signal sonore sur la dernière partie de descente • Vanne d'arrêt en cas de rupture de la tuyauterie • Commandes de type homme mort à 24 V • Déclenchement automatique des crochets lors de la descente
-  Alta velocidad de elevación • Seguridad hidráulica contra la sobrecarga • Válvula de regulación del descenso • Señal acústica último tramo de descenso • Seguridad hidráulica en caso de rotura tubos hidráulicos • Mandos de hombre presente, 24V • Desenganche automático de las seguridades para el descenso

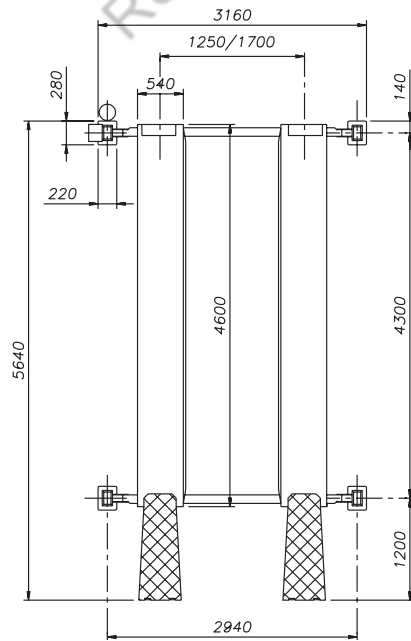
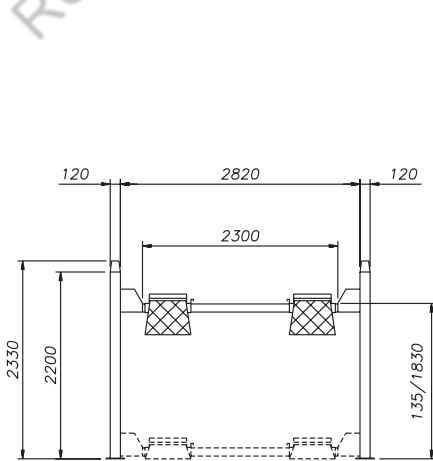
**Dati tecnici****Technical data****Technische Eigenschaften****Caractéristiques techniques****Datos técnicos**

Portata	Capacity	Tragfähigkeit	Capacité	Capacidad	4.000 kg
Peso	Weight	Gewicht	Poids	Peso	980 kg
Salita/Discesa	Lifting/descent	Hub/Senkzeit	Levage/descente	Subida/Bajada	30 s
Altezza di sollevamento	Lifting height	Hubhöhe	Hauteur de levage	Altura de elevación	1830 mm
Motore	Motor	Motorleistung	Puissance moteur	Motor	3,0 kW - 3 ph 230 400V/50 Hz

Funzionamento: Elettroidraulico • **Function: Electro-hydraulic** • Funktionsweise: Elektrohydraulisch • Fonctionnement: Electrohydraulique
• Funcionamiento: Electro-hidráulico

Opzioni**Optionals****Sonderzubehör****Options****Opcionales**

Traversa idraulica ausiliaria (vedere scheda specifica)
Hydraulic jacking beam (see relevant data sheet)
Hydraulischer Radfreiheber (s. eigenes Datenblatt)
Levage auxiliaire hydraulique (voir fiche technique)
Elevador hidráulico auxiliar (ver ficha técnica)

Esecuzione con motore monofase • Kit illuminazione • Carter protezione centralina • Disponibili versioni corrispondenti a normative specifiche (M.O.T.)

Single-phase motor • Illumination kit • Cover for control unit • Available with specific M.O.T. norms upon request

Ausführung mit Einphasenmotor • Beleuchtungsset • Abdeckung für Hydraulikaggregat • Es sind Ausführungen nach spezifischen Normen lieferbar (M.O.T.)

Moteur monophasé • Kit d'éclairage • Carter protection centrale hydraulique • On peut livrer versions correspondantes à normes spécifiques (M.O.T.)

Motor monofásico • Kit de iluminación • Cubierta protectora para la centralita • Disponibles versiones correspondientes a normas específicas (M.O.T.)