



# Ravaglioli

COMPANY WITH  
QUALITY SYSTEM  
CERTIFIED BY DNV GL  
= ISO 9001 =

## BIKE & BIKE



KP

1394

1396

G

7240.

BIKE

G

1.111

2.116





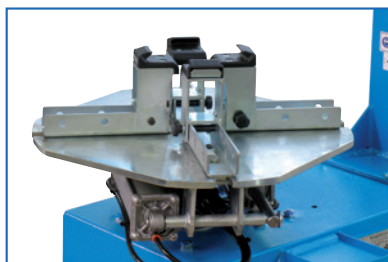
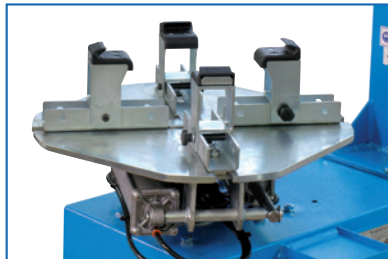

**G7240.BIKE**

Шиномонтажный стенд разработан специально для колес мотоциклов.

*Tyre changers especially designed to handle motorcycle wheels.*

Reifenmontiergeräte speziell ausgestattet für die Montage von Motorrädern.

*Démonte-pneus avec équipement spécial pour les roues moto.*

Smontagomme specialmente allestiti per lo smontaggio di ruote da moto.

**G7240.BIKE**

Наружный зажим

*External clamping*

*Aussengespannt*

*Blocage extérieur*

*Bloccaggio esterno*

5" - 24"



G7240.BIKE

**G1.111**

Компактный стенд с ручным приводом. Однократное измерение с низкой скоростью вращения.

*Compact hand spin machine. Single launch measurement with low rotation speed.*

Kompaktmaschine mit manuellem Anwurf. Einzelner Messvorgang mit niedriger Drehgeschwindigkeit.

*Equilibreuse à lancement manuel. Mesure avec un seul lancement à basse vitesse de rotation.*

Macchina compatta a lancio manuale. Macchina compatta a lancio manuale.



G1.111  
+GAR181  
+GAR181A1

**Опции GAR 181**



**G2.116**

Электронный компьютеризированный балансировочный стенд с прекрасными характеристиками скорости и точности измерения. Запускается одномоторным приводом с автоматической остановкой в конце цикла.

*Electronic computerised wheel balancer with high performances in terms of rapidity and accuracy. Single motor driven launch with automatic stop at the end of the cycle.*

Computer gesteuerte Wuchtmaschine für ein präzises und schnelles Wuchten. Einzelner Messvorgang mit automatischer Abbremsung am Ende, Motor getrieben.

*Equilibreuse électronique à microprocesseur avec prestations de rapidité et précision. Un seul lancement par moteur et arrêt automatique en fin de cycle.*

Equilibratrice elettronica computerizzata con elevate prestazioni di rapidità e precisione. Lancio unico a motore e arresto automatico a fine ciclo.

**Опции GAR 181+GAR 191**



GAR181A1

GAR181 > 14 mm





KP1394 + S1394 A1

**KP1394 - KP1394P / kg 400**

Пантографный подъемник с ножным гидравлическим насосом (KP1394) или с пневмогидравлическим насосом (KP1394P). Высота подъема 800 мм.

*Pantograph lift with foot-operated hydraulic pump (KP1394) or with air-hydraulic pump (KP1394P). Lifting height of 800mm.*

Parallelogrammbühne mit hydraulischer Fusspumpe (KP1394) oder mit lufthydraulischer Pumpe. Optimale Hubhöhe von 800 mm.

*Élévateurs à pantographe avec pompe hydraulique à pédale (KP1394) ou pompe hydropneumatique (KP1394P). Hauteur de levage optimale de 800 mm.*

Sollevatore a pantografo con pompa idraulica a pedale (KP1394) o con pompa oleopneumatica (KP1394P). Altezza di sollevamento ottimale di 800 mm.



KP1394P + S1394 A1

**Easy Wheel Service**

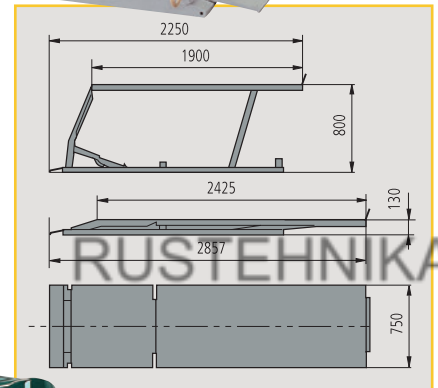

**ОПЦИИ**

S 1394A1



S 1394A2

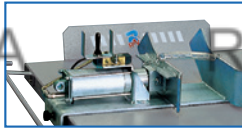

**KP1396P - KP1396E / kg 600**

Ножничный подъемник с пневмогидравлическим насосом (KP1396P) или с электрогидравлической насосом с панелью управления (KP1396E). Высокий уровень подъема - 1000 мм.

*Scissors lift with air-hydraulic pump (KP1396P) or with electro-hydraulic control box (KP1396E). Great lifting height of 1000 mm.*

Scherenhebebühne mit lufthydraulischer Pumpe (KP1396P) oder elektrohydraulisch (KP1396E). Bemerkenswerte Hubhöhe 1.000 mm.

*Élévateurs à ciseau avec pompe hydropneumatique (KP1396P) ou pompe électro-hydraulique (KP1396E). Hauteur de levage importante de 1.000 mm.*

Sollevatore a forbice con pompa oleopneumatica (KP1396P) o con centralina elettro-idraulica (KP1396E). Notevole altezza di sollevamento di 1.000 mm.

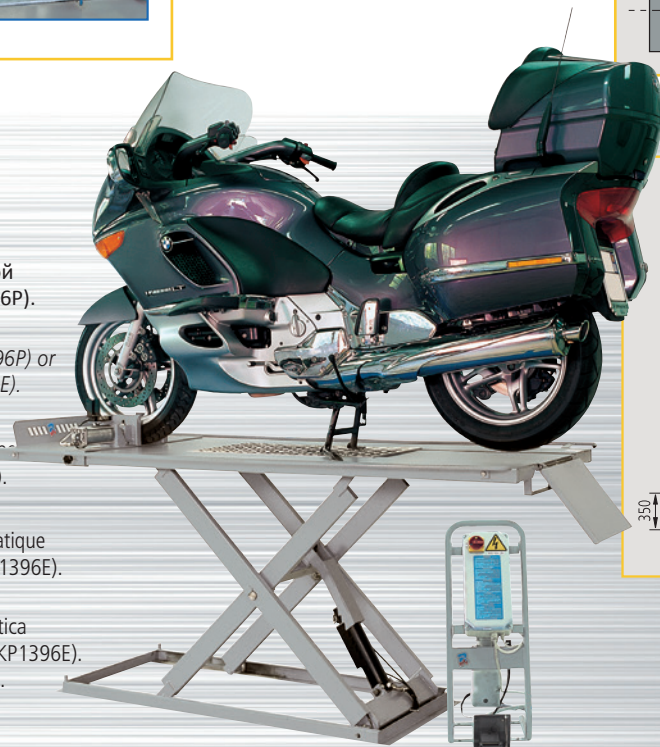

KP 1396E + S 1394 A2

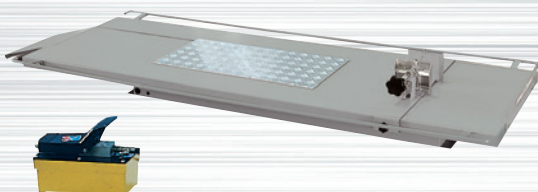
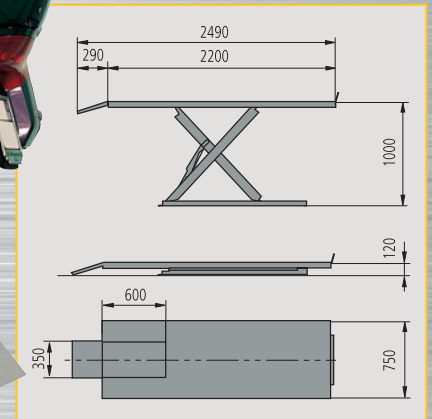

KP 1396P + S 1394 A1



**Easy Wheel Service**



**KP1394T - KP1394TP / кг 400**

Подъемник с широкой платформой (1000 мм) для подъема мотоциклов и легкой садовой техники.

Wide platform (1000 mm) to lift garden machinery.

Bühnen mit breiter Aufnahmefläche (1000 mm) zum Heben von Motorrädern und Gartengeräte.

Élévateurs avec plateforme plus large (1.000 mm) pour le levage de motos et motoculteurs.

Sollevatori con pedana di larghezza maggiorata (1000 mm) per il sollevamento di moto e macchine da giardinaggio.

KP1394T	KP1394TP
Подъемник с ножным гидравлич. насосом	Подъемник с пневмогидравлич. насосом
Lift with foot-operated hydraulic pump	Lift with air-hydraulic pump
Bühne mit hydraulischer Fusspumpe	Bühne mit lufthydraulischer Pumpe
Élévateur avec pompe hydraulique à pédale	Élévateur avec pompe hydro-pneumatique
Sollevatore con pompa idraulica a pedale	Sollevatore con pompa oleopneumatica

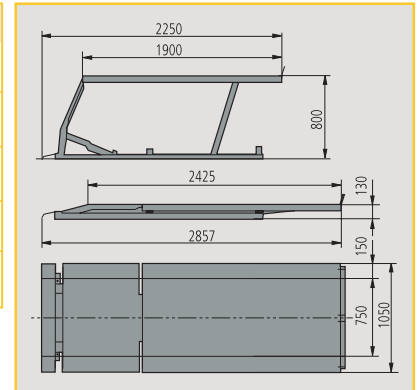

**KP1396TP - KP1396TE / кг 600**

Подъемник с широкой платформой (1450 мм.) для подъема 3-колесной техники, квадроциклов и микро-автомобилей.

Very wide platform (1450 mm) to lift 3-wheel vehicles and micro-cars.

Bühnen mit breiter Aufnahmefläche (1450 mm) zum Heben von Dreirädern und Kleinfahrzeugen.

Élévateurs avec plateforme extra-large (1450 mm) pour levage de triporteurs et microvoitures.

Sollevatori con pedana di larghezza maggiorata (1450 mm) per il sollevamento di tricicli e quadricicli/microvetture.

KP1396TP	KP1396TE
Подъемник с ножным гидравлич. насосом	Подъемник с пневмогидравлич. насосом
Scissors lift with air-hydraulic pump	Scissors lift with electro-hydraulic pump
Bühne mit lufthydraulischer Pumpe	Bühne mit elektrohydraulischer Pumpe
Élévateurs avec pompe hydro-pneumatique	Élévateurs avec pompe électro-hydraulique
Sollevatore con pompa oleopneumatica	Sollevatore con pompa elettroidraulica

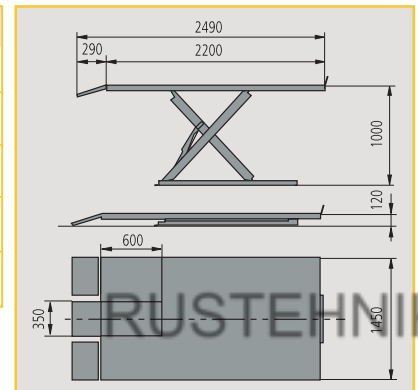

**ЛИНИЯ ДИАГНОСТИКИ МОТОЦИКЛОВ**



**Ravaglioli S.p.A.**

40037 Sasso Marconi  
Fraz. Pontecchio M.  
P.O.B. 1690 - Bologna - Italia  
Tel. +39 - 051 - 6781511  
Fax +39 - 051 - 846349  
rav@ravaglioli.com  
www.ravaglioli.com

**RAV France**

6, Rue Longue Raie  
ZAC de la Tremblaie  
91220 Le Plessis Pâté  
Tel. 01.60.86.88.16  
Fax. 01.60.86.82.04  
rav@ravfrance.fr

**Ravaglioli Deutschland**

Kirchenpoint 22  
85354 Freising  
Tel. 08165-646956  
Fax 08165-646958  
info@ravaglioli.de

**RAV Equipment UK LTD**

Prince Albert House  
20 King Street  
Maidenhead, SL6 1DT  
Tel. 020-76286832  
Fax 020-76286833  
ravuk@ravaglioli.com

**RAV en Belgique**

Nederlandstalig  
Tel. 0498-162016  
Fax 016-781025  
Zone Francophone  
Tel. 0498-163016  
Fax +32 78 055 030

**RAV Equipos España**

Avenida Europa 17  
Pol. Ind. de Constanti  
Tarragona 43120  
Tel. 977 524525  
Fax 977 524532  
ravequipos@ravaglioli.e.telefonica.net

DRN30U (2)

