



Installation And Service Manual

RUSTEHNKA

RUSTEHNKA

RUSTEHNKA

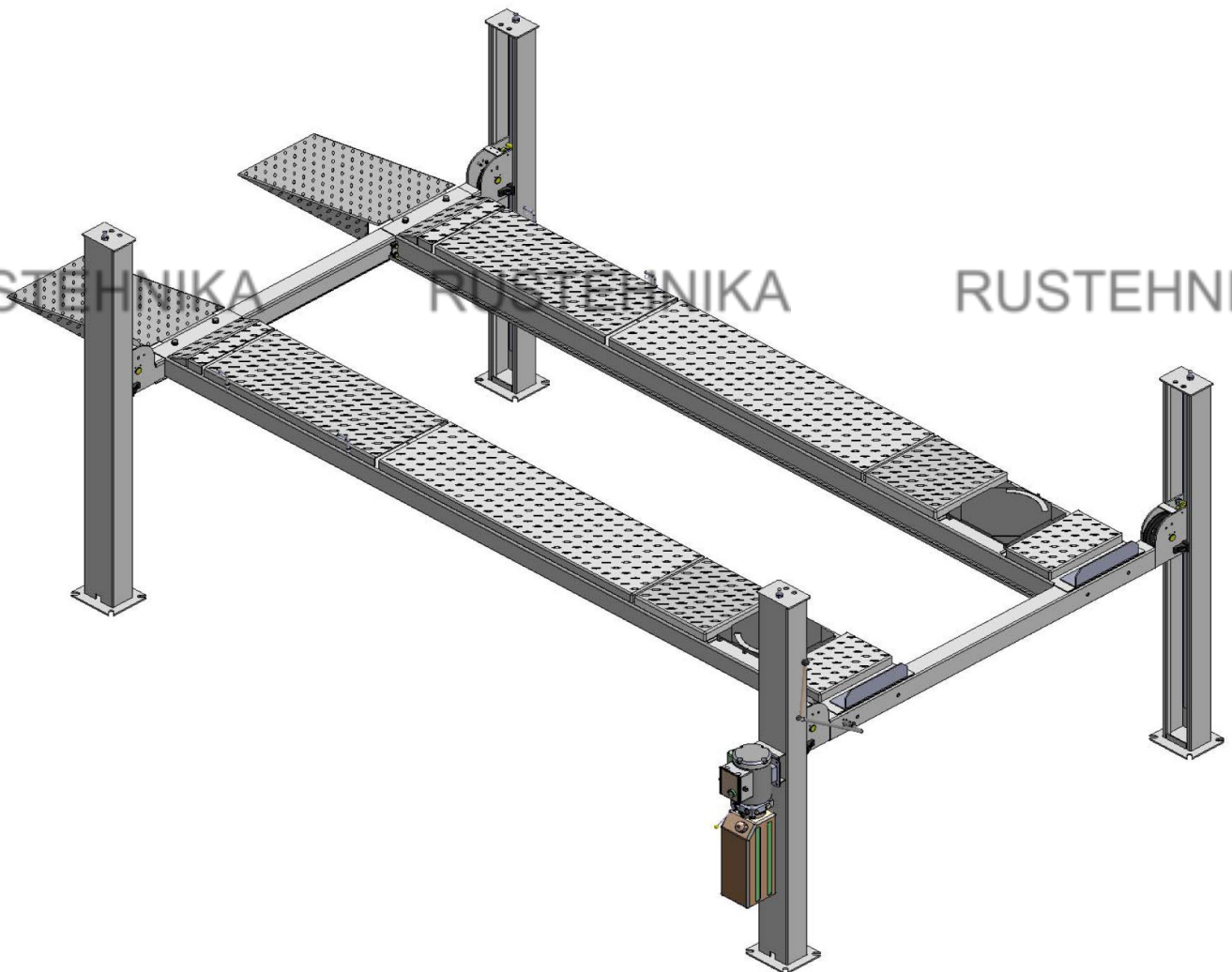

FOUR POST LIFT Model: KHL-4000A

CONTENTS

Product Features and Specifications	1
Installation Requirement	2
Steps of Installation	3
Exploded View	23
Test Run	28
Operation Instruction	29
Maintenance	29
Trouble Shooting	30
Parts List	31

I. PRODUCT FEATURES AND SPECIFICATIONS

ALIGNMENT 4-POST MODEL KHL-4000A FEATURES

- Single point manual safety release.
- Double safety devices: Mechanical self-lock and cable-breaking protection lock.
- Non-skid diamond platforms and adjustable safety lock ladders.
- Multiple turnplate pockets fit with different wheel base.

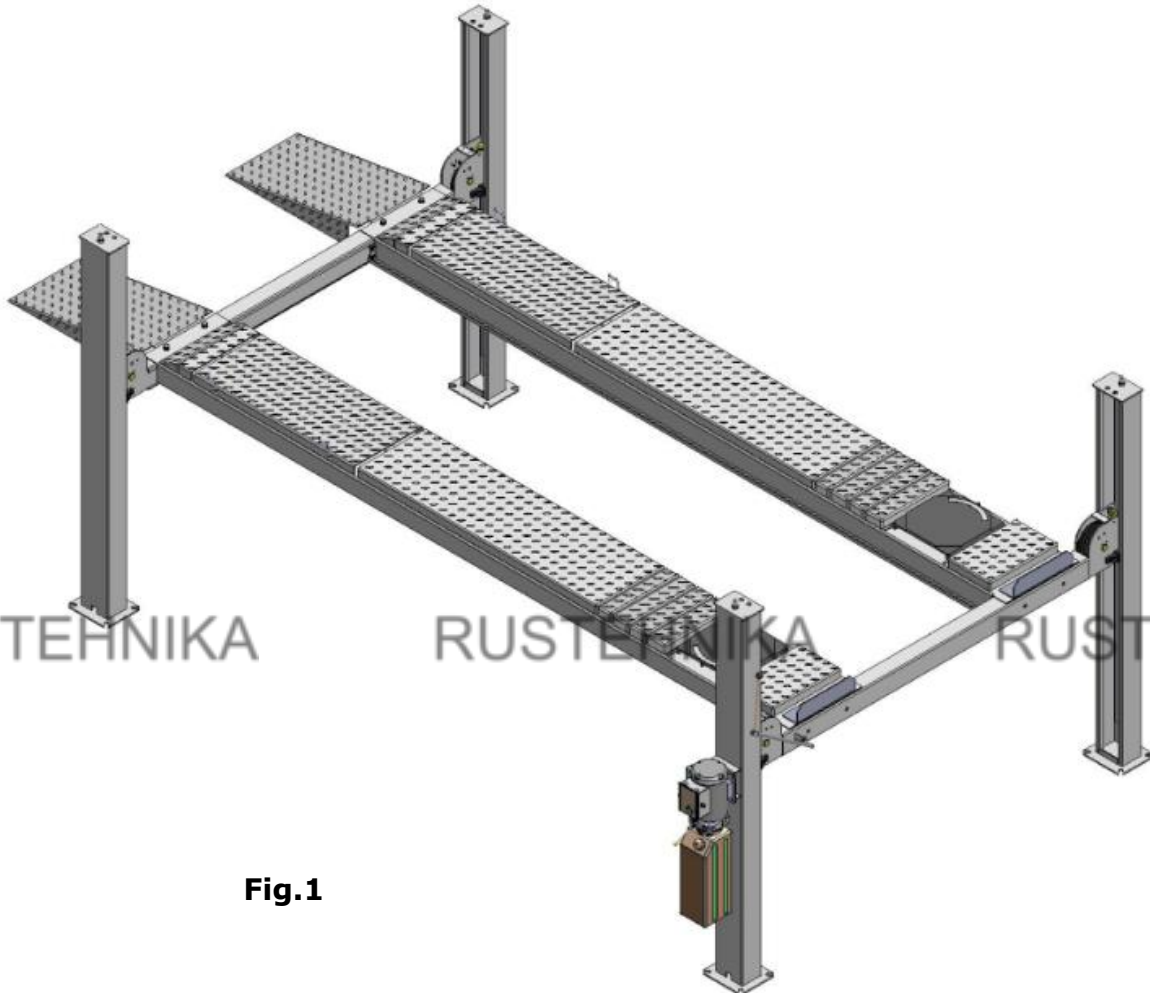

Fig.1

MODEL KHL-4000A SPECIFICATIONS

Model	Lift Capacity	Lifting Height	Lifting Time	Overall Length (Inc. Ramps)	Overall Width	Width Between Columns	Gross Weight	Motor
KHL-4000A	4.0T (9,000 lbs)	1922mm (75 1/2")	47S	5457mm (214")	3206mm (126 1/4")	2846mm (112 ")	1057kg (2230 lbs)	220V/3.0HP

II. INSTALLATION REQUIREMENT

A. TOOLS REQUIRED

✓ Tape Measure (7.5m)



✓ Hammer



✓ Level Bar



✓ English Spanner (12")



✓ Wrench set: (12#, 13#, 14#, 15#, 17#, 19#, 24#, 30#)



✓ Carpenter's Chalk



✓ Screw Sets



✓ Pliers



✓ Lock Wrench



✓ Socket Head Wrench: (3#, 5#, 6#, 8#)



Fig.2

B. SPECIFICATIONS OF CONCRETE (See Fig. 3)

Specifications of concrete must be adhered to the specification as following.

Failure to do so may result in lift and/or vehicle falling.

1. Concrete must be thickness 100mm minimum and without reinforcing steel bars, and must be dried completely before the installation.
2. Concrete must be in good condition and must be of test strength 3,000psi (210kg/cm²) minimum.
3. Floors must be level and no cracks.

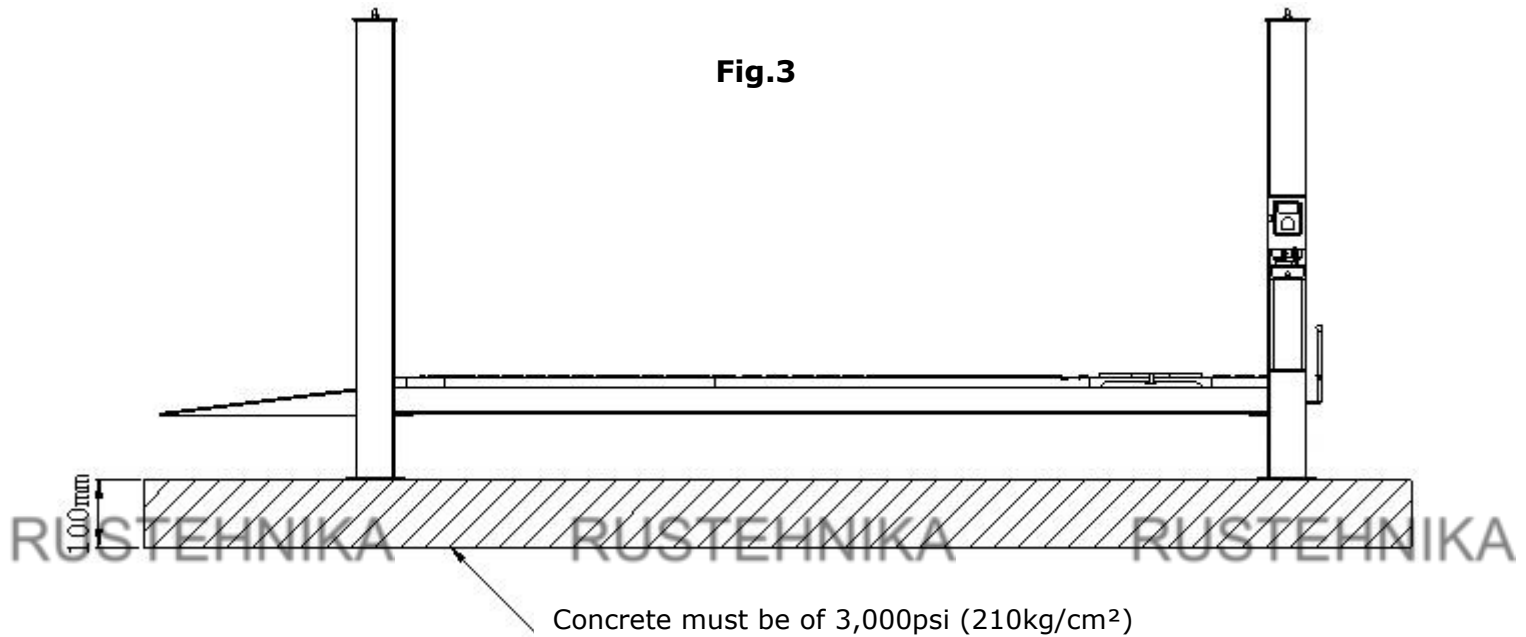
**C. POWER SUPPLY**

The electrical source must be 2.2KW minimum. The source cable size must be 2.5mm² and in good condition of contacting with floor.

III. STEPS OF INSTALLATION**A. Check the parts before assembly**

1. Packaged lift and Hydraulic Power Unit (See Fig. 4).



Fig.4

2. Open the outer packing carefully, check the parts according to the shipment list. (See Fig. 5).

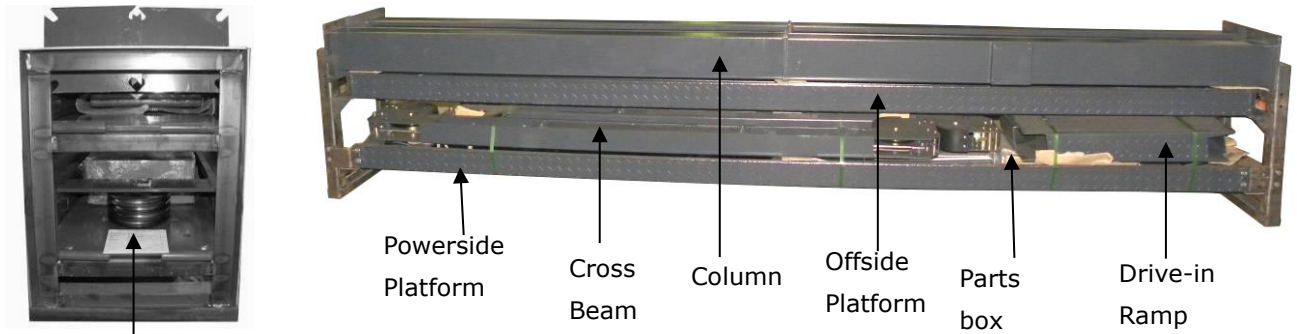

Fig.5

3. Take off the drive-in ramps and columns (See Fig.6)

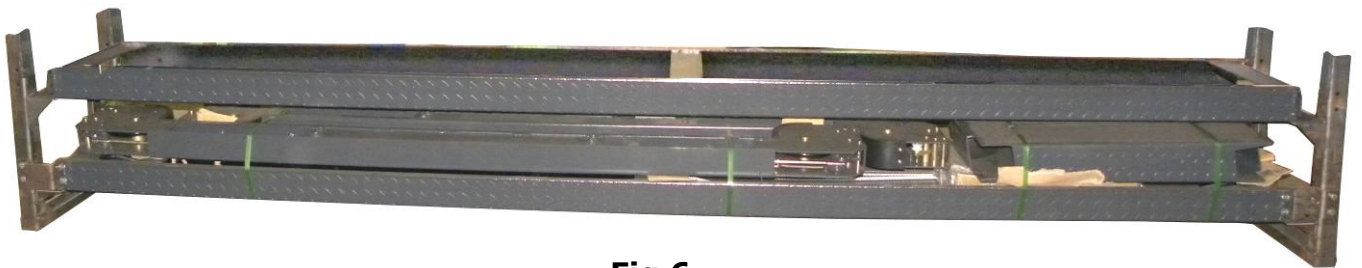

Fig.6

4. Loosen the screws of the upper package stand, take off the offside platform, take out the parts inside the powerside platform, then remove the package stand.

5. Move aside the parts and check the parts according to the shipment parts list

(See Fig. 7).

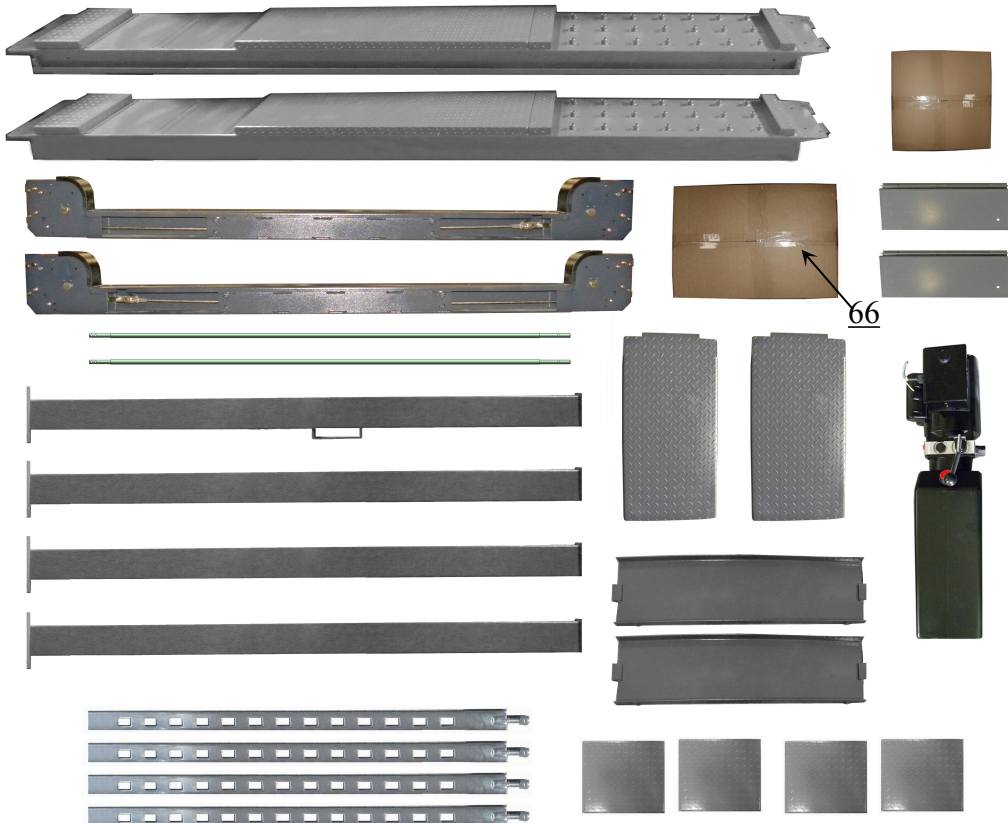

Fig.7

6. Open the carton of parts and check the parts according to the parts box list (See Fig. 8).



Fig.8

7. Check the parts of the parts bag according to the parts bag list (See Fig. 9).

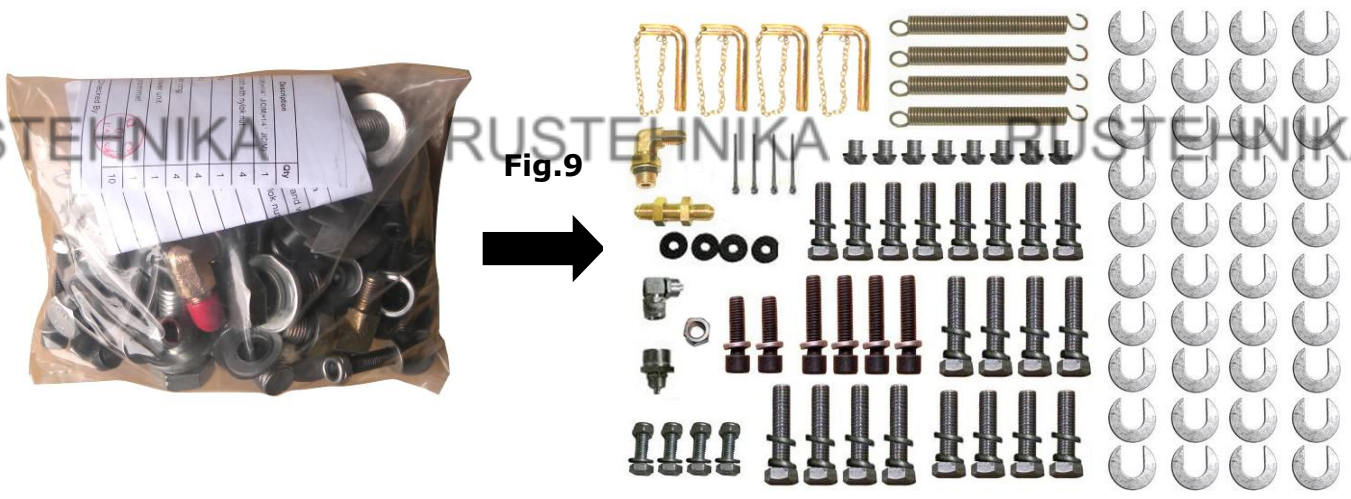

Fig.9

B. Use a carpenter’s chalk line to establish installation layout as per Table 1
 Make sure the size is right and base is flat (**see Fig. 10**).

Note: Reserve space in front and behind the installation site.

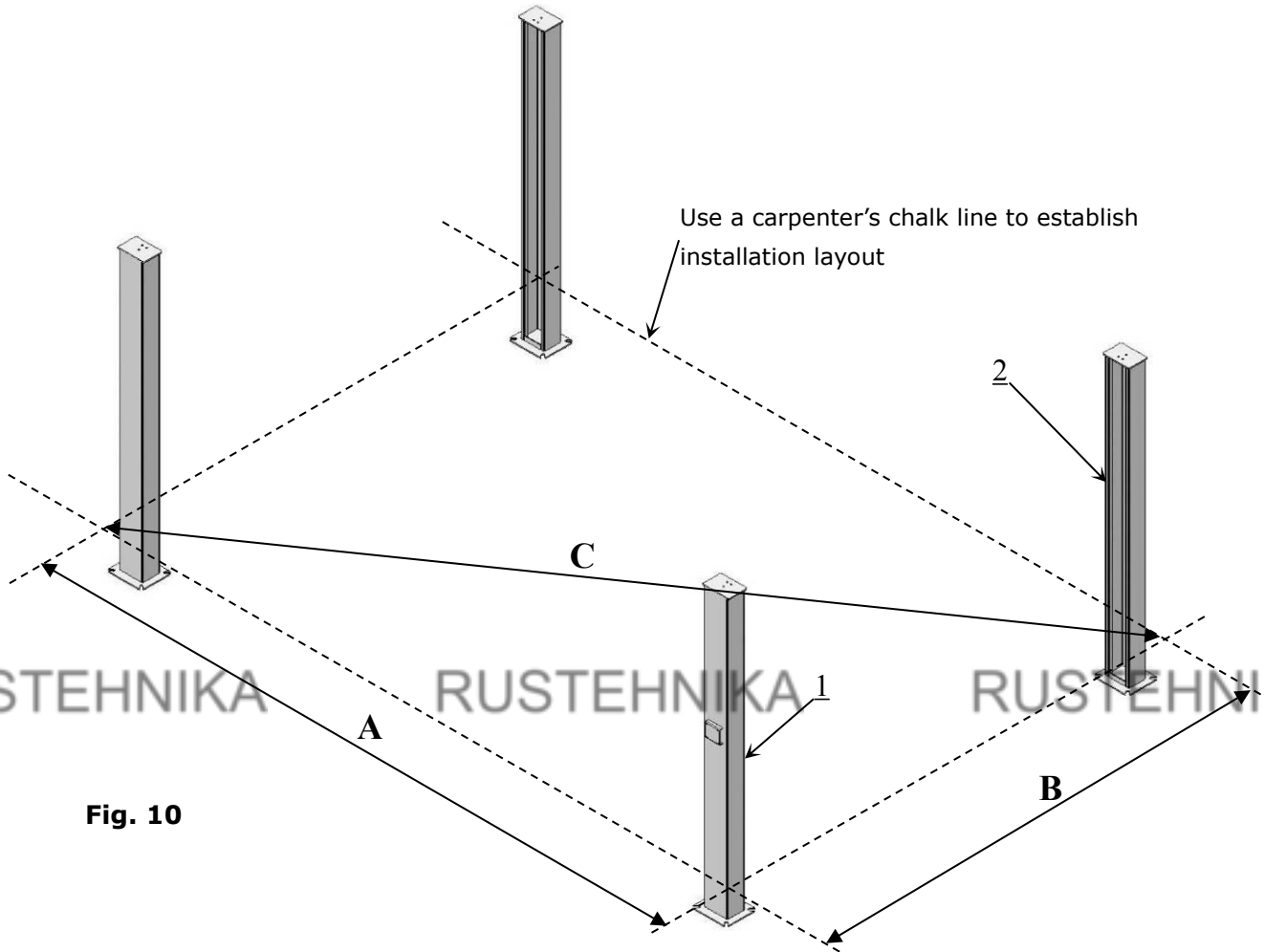

Fig. 10

Model	A	B	C
KHL-4000A	4600mm 181"	3206mm 126 1/4"	5607mm 220"

C. Install cross beams (See Fig.11, Fig.12).

Note: Pay attention that the cross beam's slot should be positioned towards inward and the safety locks connecting assy. should be adjacent to the power unit column.

The power unit column should be adjacent to the safety locks connecting assy.

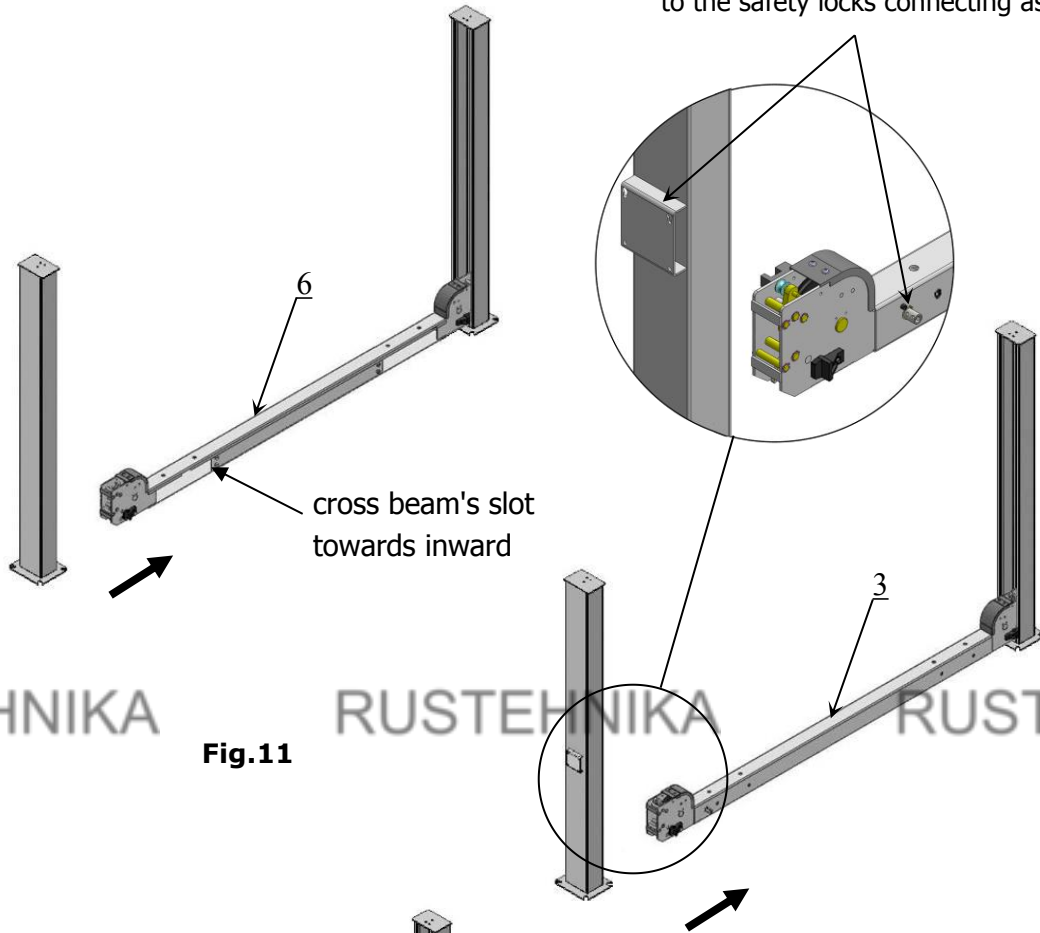

Fig.11

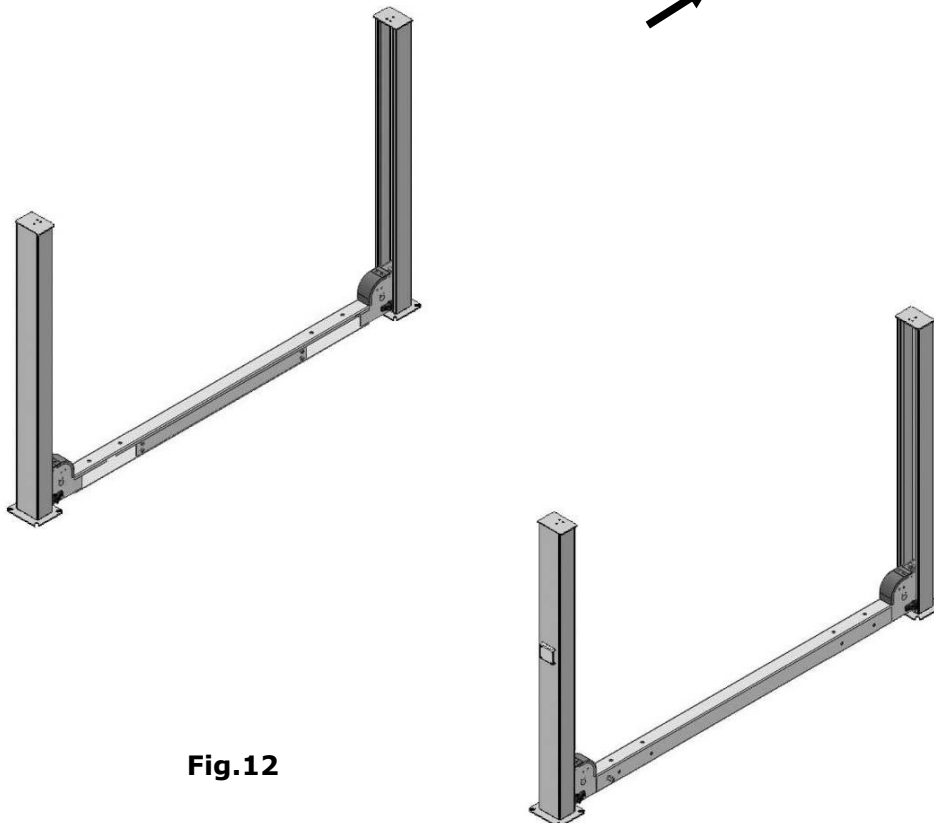

Fig.12

C. Fix the anchor bolts

1. Prepare the anchor bolts (**See Fig. 13**)

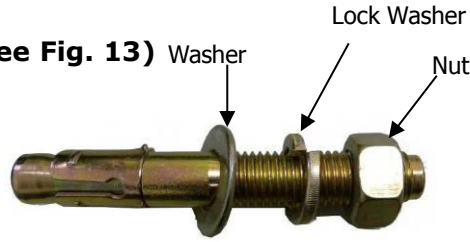

Fig.13

2. Using the prescribed hammer drill to drill all the anchor holes and install the anchor bolts.

Do not tighten the anchor bolts (**See Fig. 14**)

Note: Tap anchor bolts into the anchor hole at least 90mm deep.

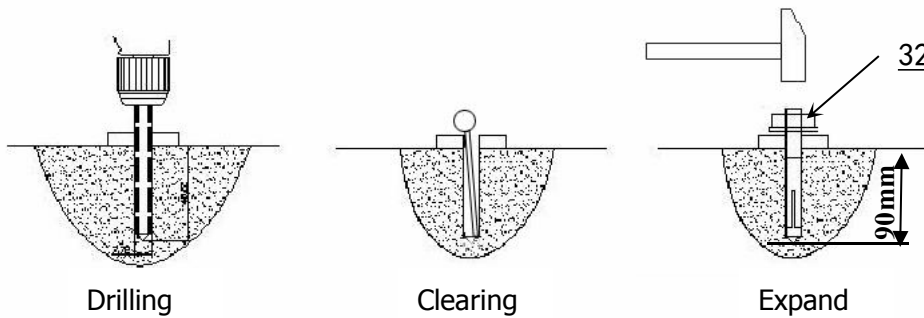

Fig.14

E. Install the Safety Ladders.

1. Unscrew the four upper nuts of the safety ladders, and then adjust the four lower nuts so they are at the same position. Then insert the safety ladders (**See Fig. 15**).

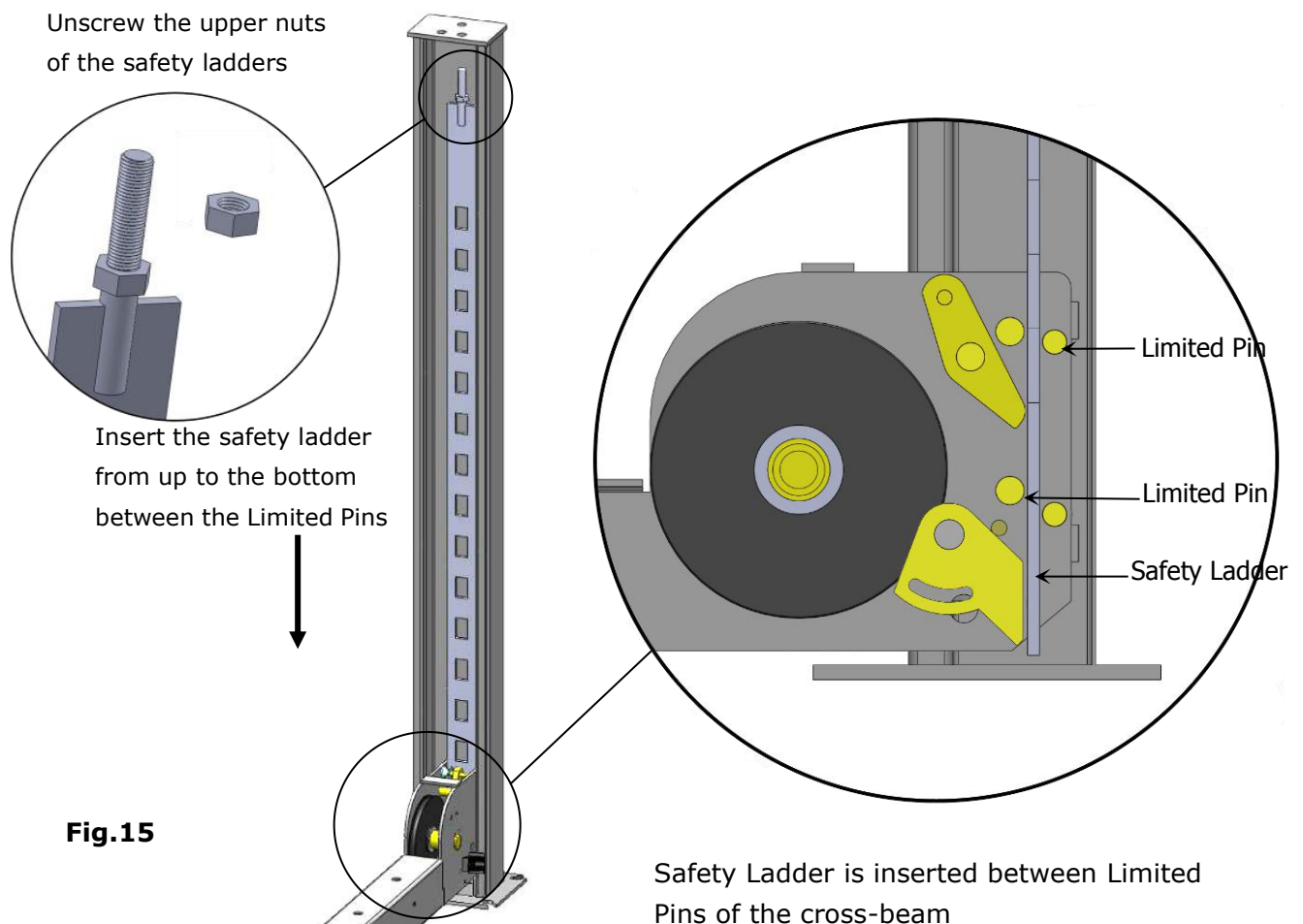
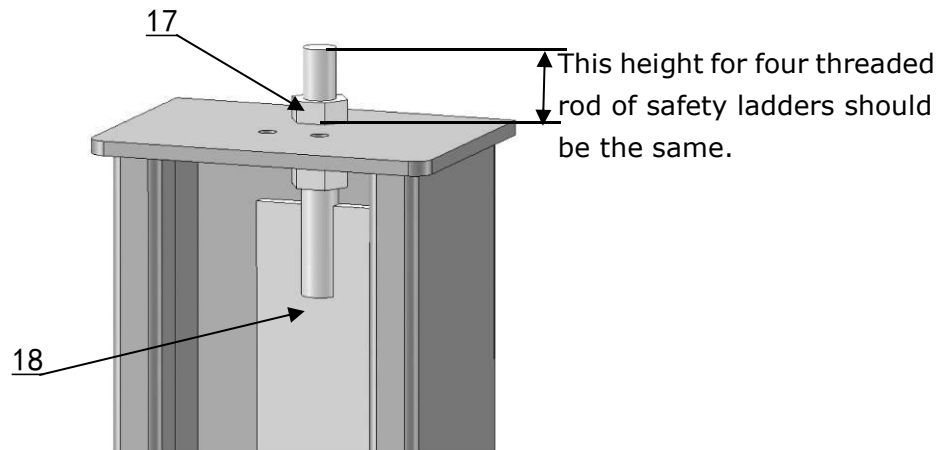

Fig.15

2. Install Safety Ladders (See Fig. 16)



Pass the threaded rod of Safety ladders through the hole of column top plate and tighten the two nuts .

Fig.16

E. Raise the cross beams at the same height and lock them on the safety ladder (See Fig. 17).

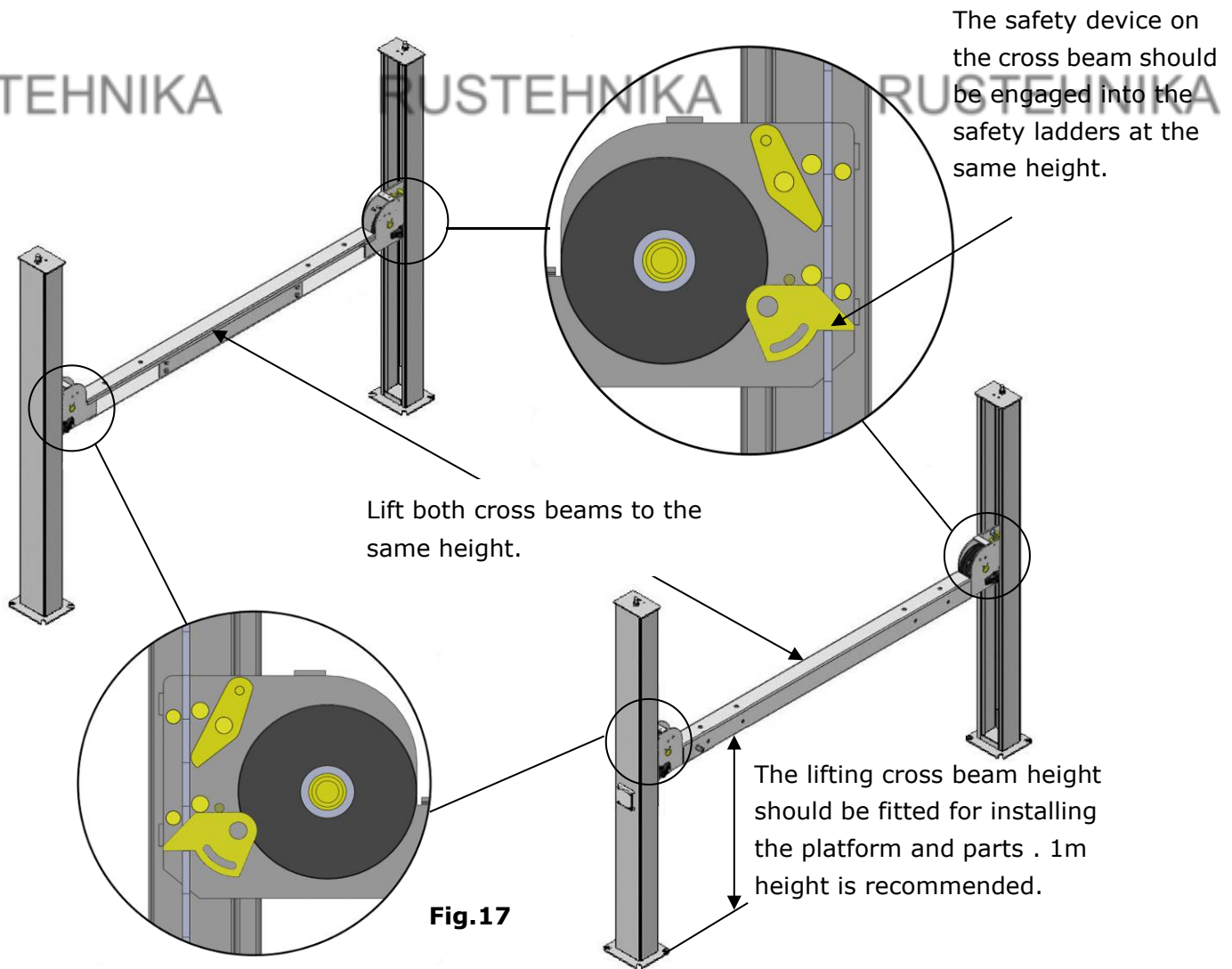
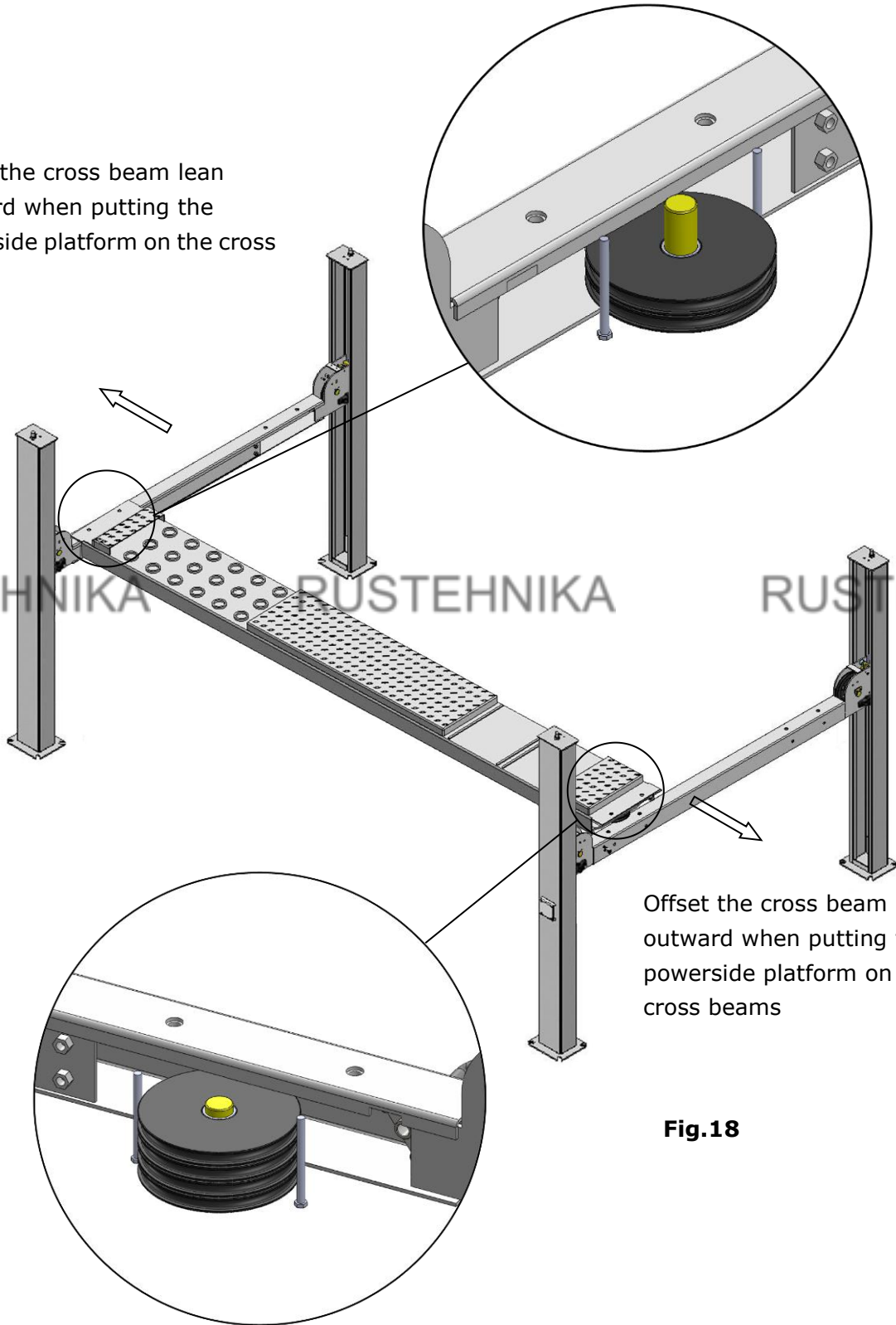

Fig.17

F. Install power side platform.

1. Raise the powerside platform above the cross beam by a forklift or crane. Then move the cross beam outwards until the pulleys of both platforms can be rested into the cross beams' slots (see **Fig.18**). Tighten the Powerside Platform to the Cross beams by using bolts.

Offset the cross beam lean outward when putting the powerside platform on the cross beams



Offset the cross beam lean outward when putting the powerside platform on the cross beams

Fig.18

2. Install the tire stop plate and connecting bolts: Tighten the platform and the cross beam **B** with bolts. Tighten the tire stop plate , platform and cross beam **A** with bolt.
 Note: Install the tire stop plate on the drive- in position . And the bolts for fixing the tire stop plate are longer, pay attention when choosing the bolts. **(See Fig.19)**

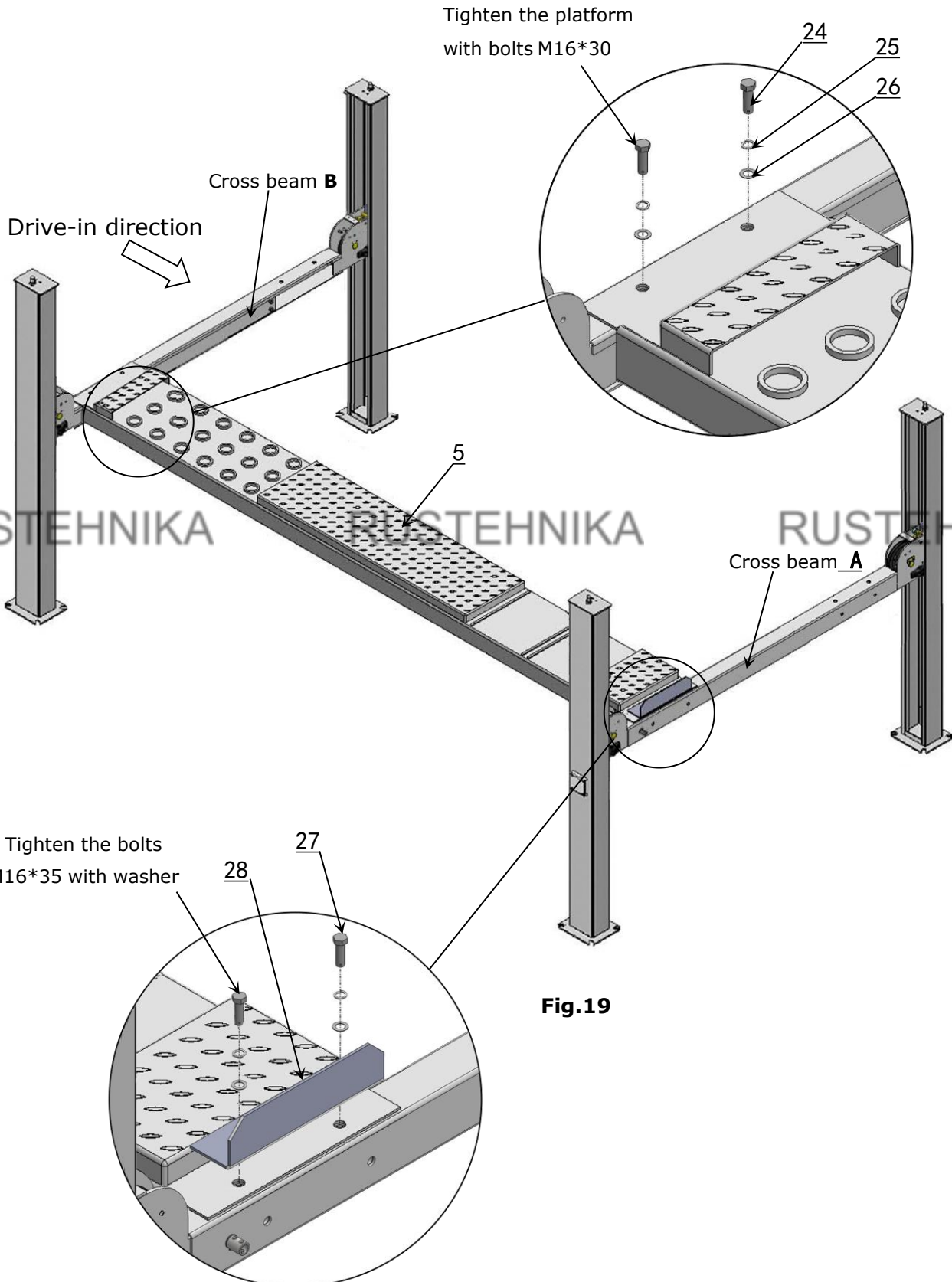
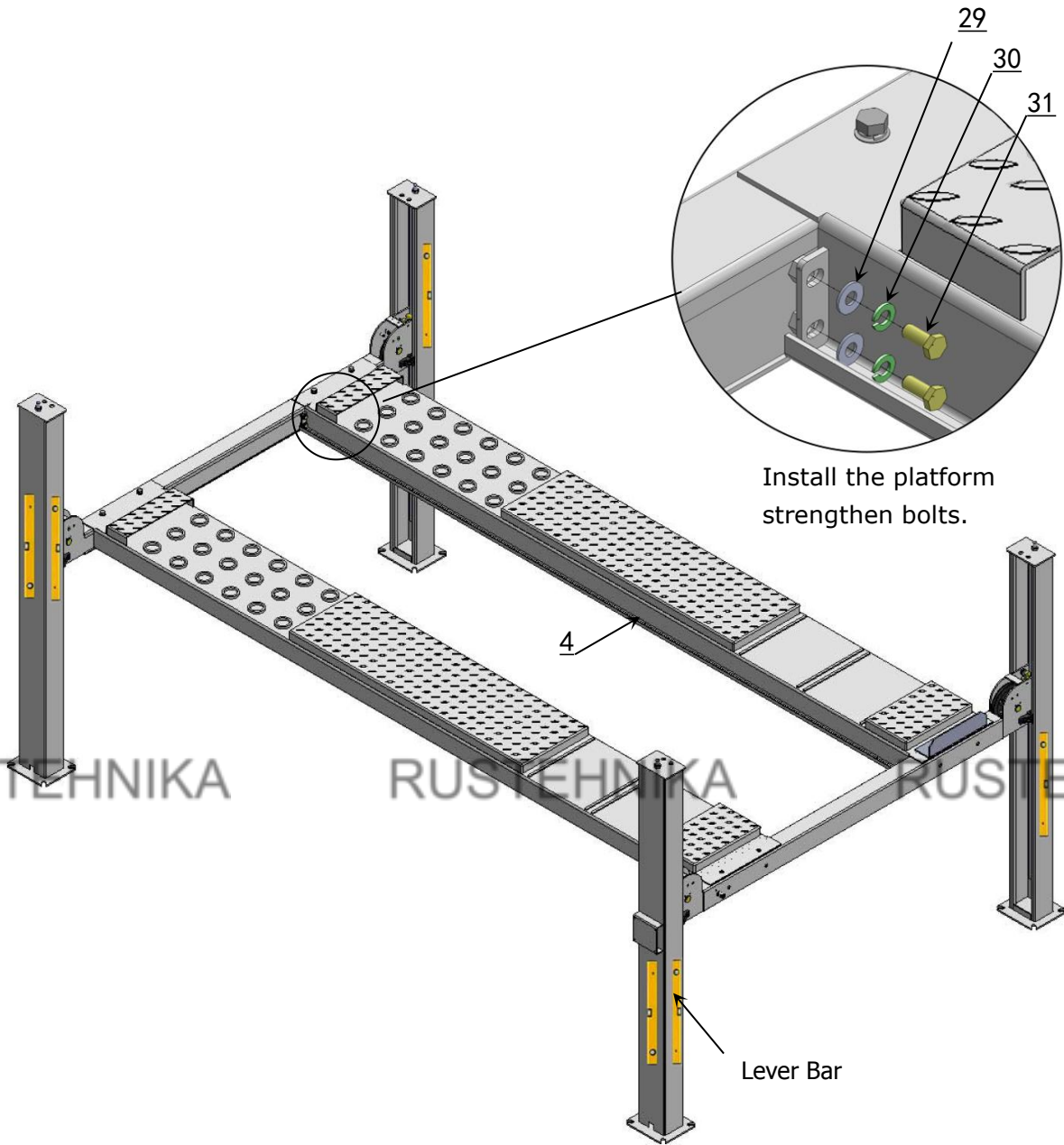

Fig.19

H. Install offside platform and platform strengthen bolts, check the verticality with level bar , adjusting with the shims and tighten the anchor screws. (See Fig. 20)



Install the platform strengthen bolts.

Lever Bar

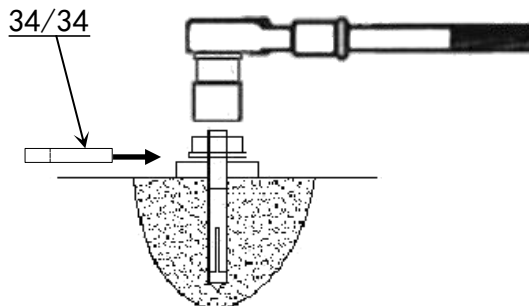

Fig.20

Tighten the anchor bolts with socket spanner.

Note: The tightening torque for anchor bolts is 150N.m

I. Illustration for cable installation

1. Connect the cable on the platform according to the cable No. to the columns accordingly.

(See Fig. 21)

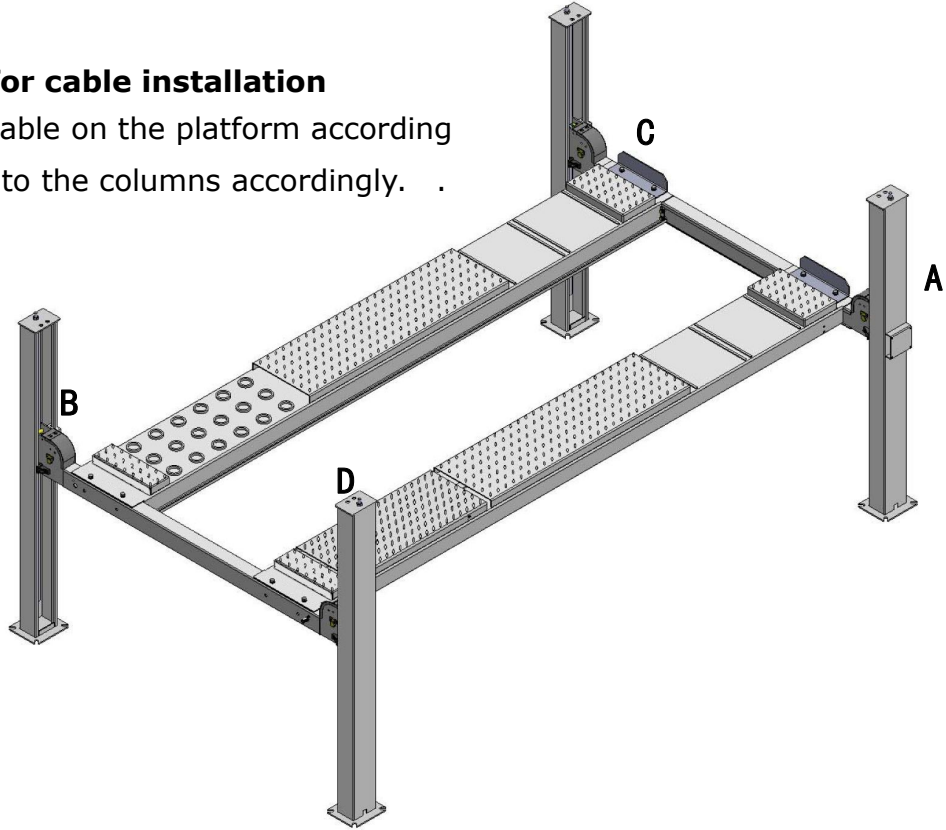

No.	①	②	③	④
Cable				
Length for 409-AH (inc. connecting fitting)	3150mm 124"	9125mm 359 1/4"	4750mm 187"	7565mm 297 5/6"

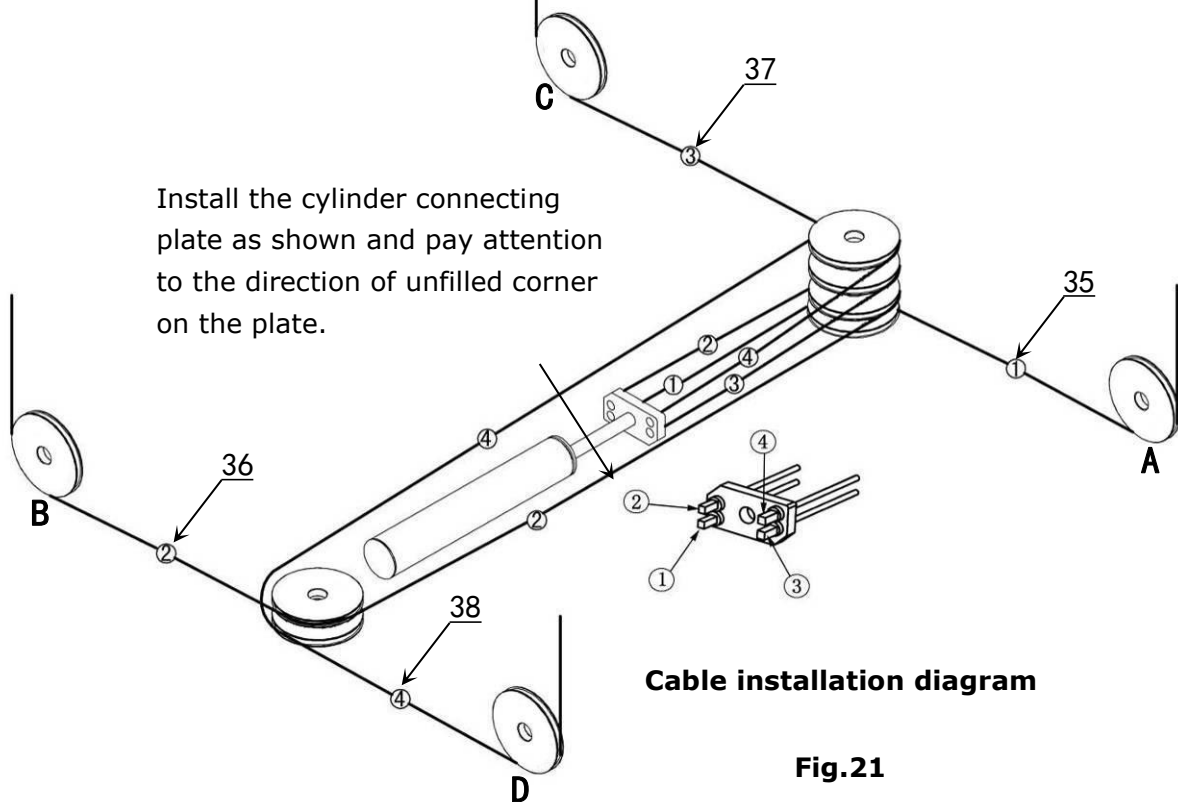
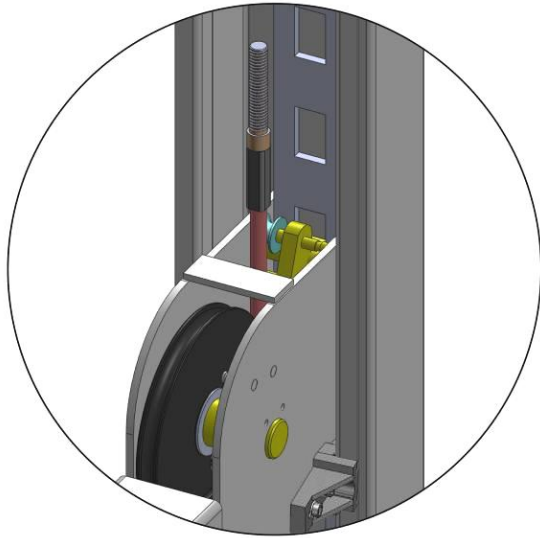
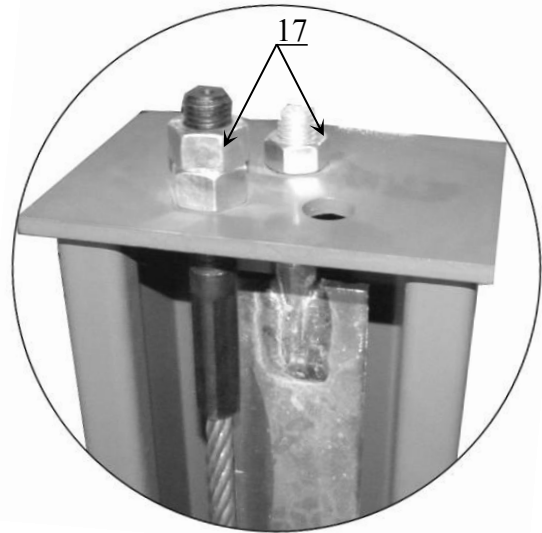

Fig.21

2. The cable goes through the cross beam to top plate of columns and tightened with cable nuts (See Fig. 22)



(1) Cable goes through the big pulley and tension pulley



(2) Cable goes through top plate and tightened with cable nuts.

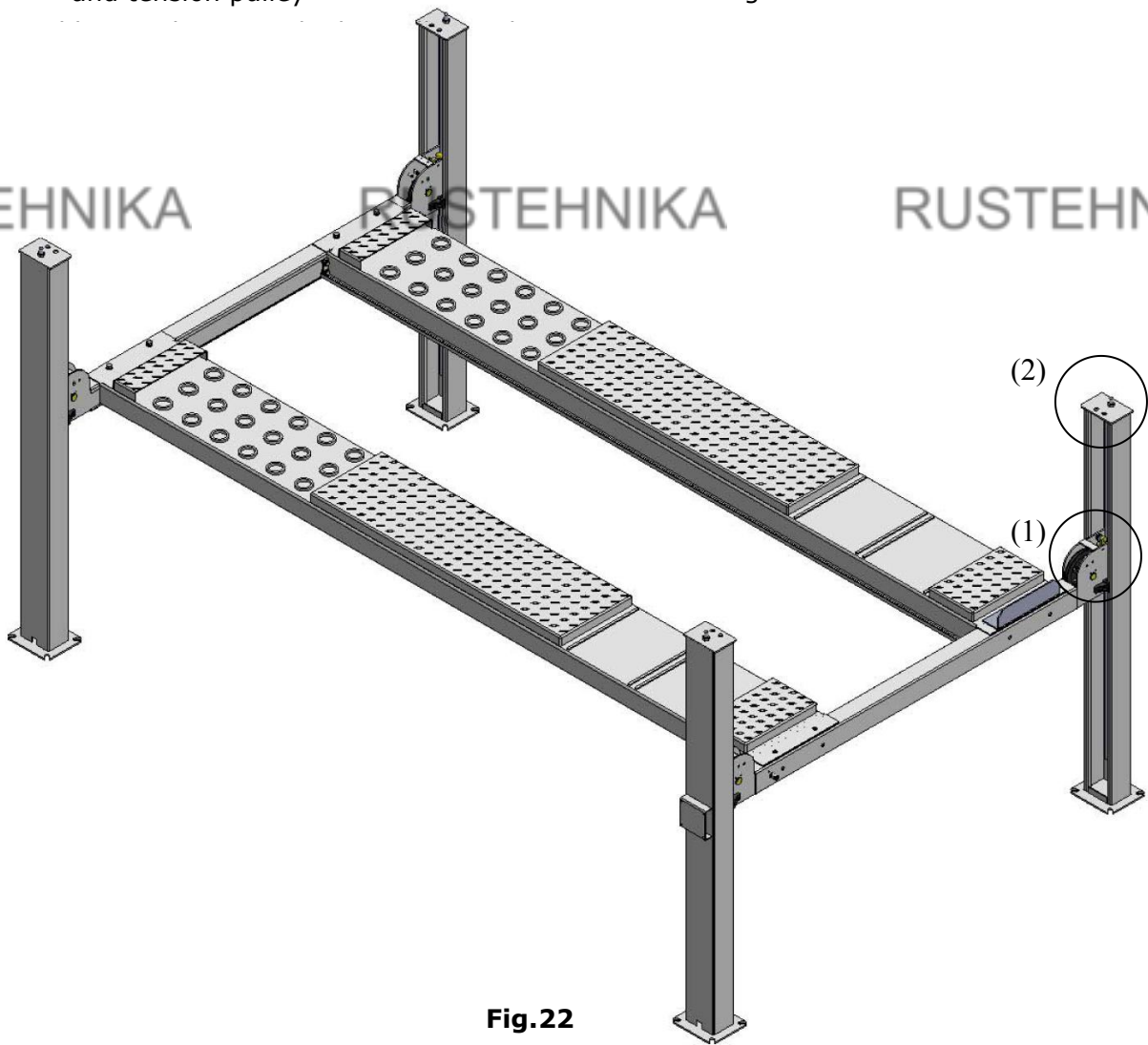

Fig.22

3. Illustration for cables under platform (See Fig. 23)

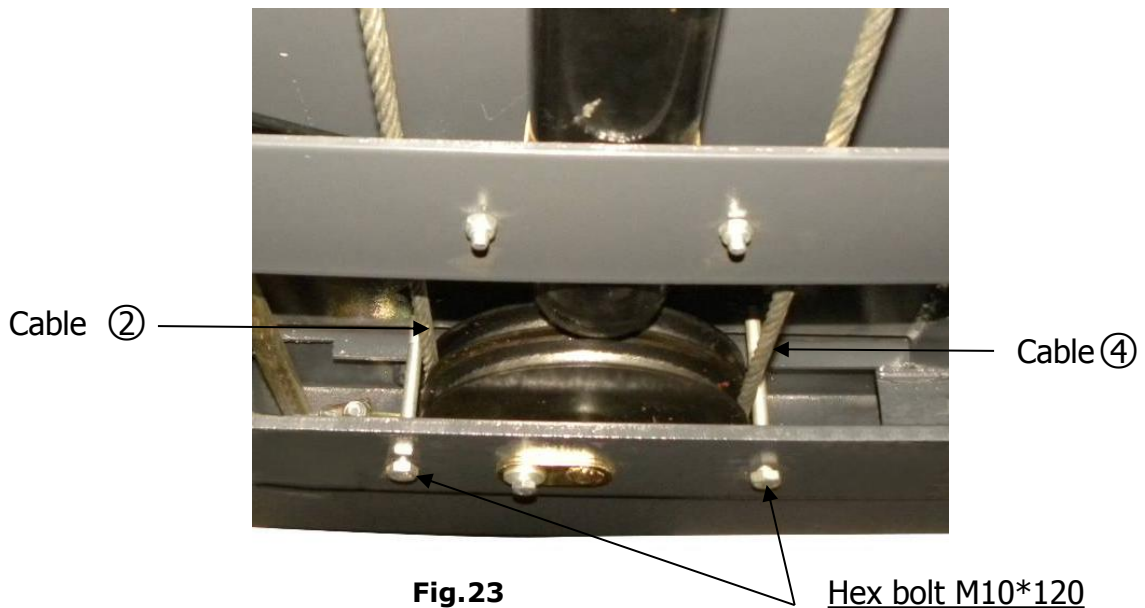
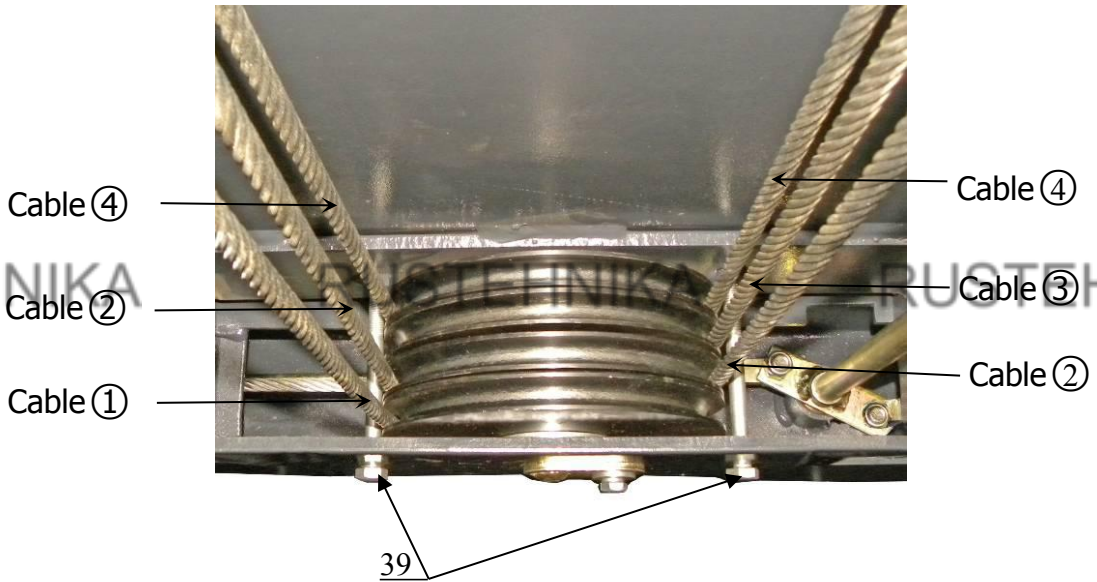
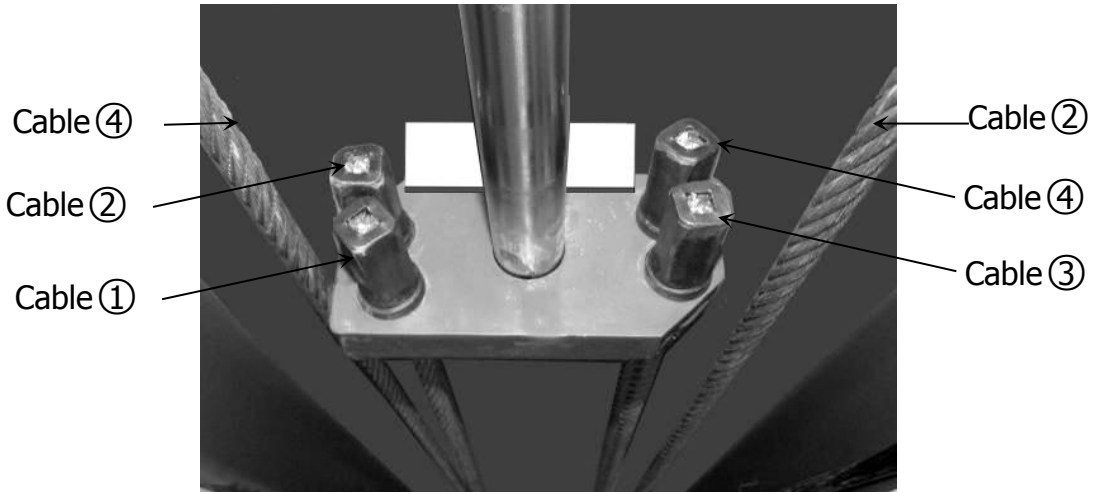
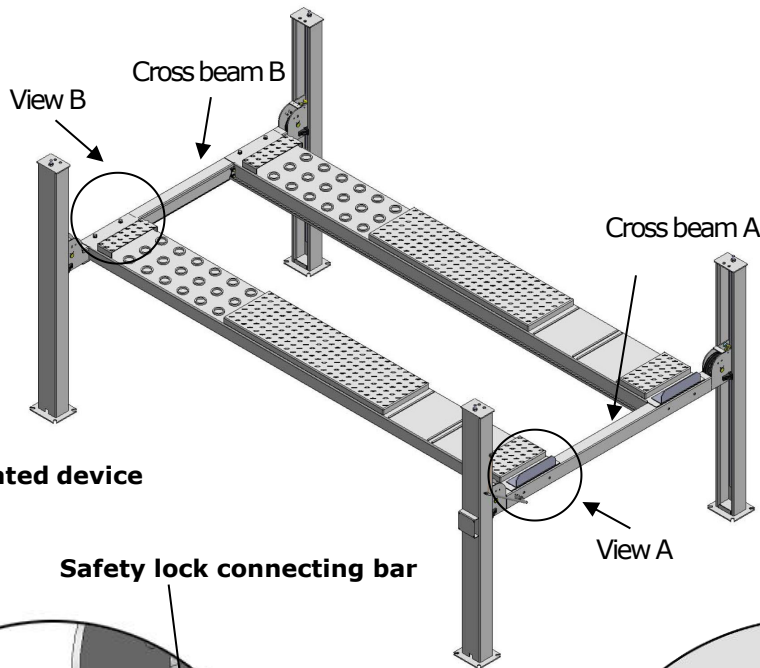

Fig.23

Hex bolt M10*120

J. Install connecting bar for safety device and release handle (See Fig. 24)



Safety lock rotated device assy.

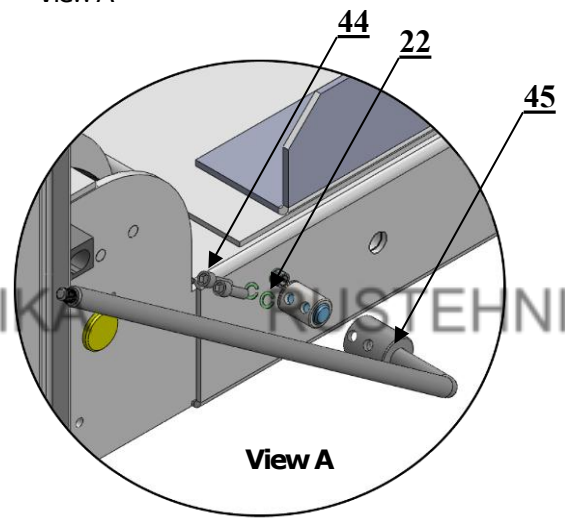
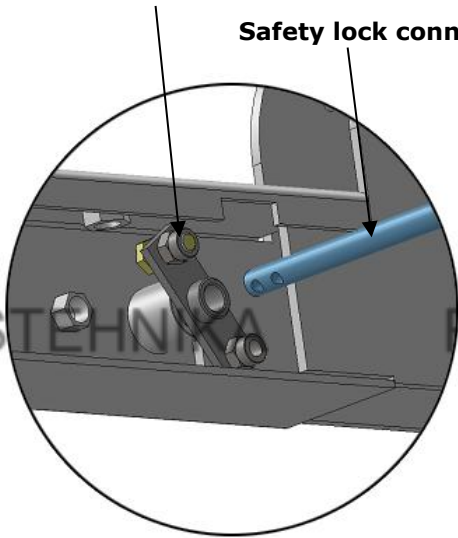

Pass through the connecting bar from the safety locks rotating assy. of cross beam **A/B**

According to the above diagram, fix lock release handle and the safety lock connecting assy. with M8*35 bolts and washers on cross beam A.

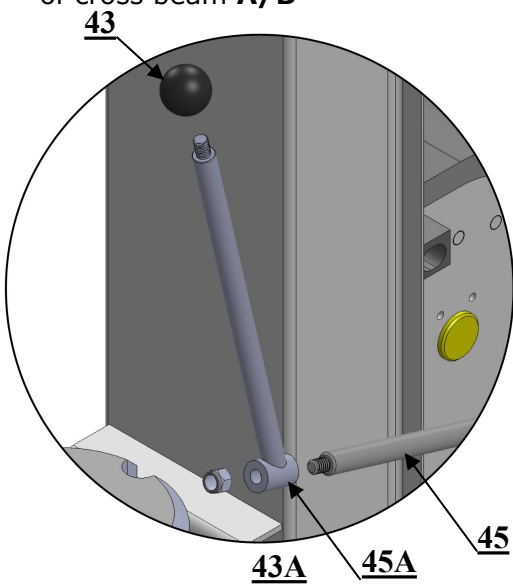

Safety lock connecting assy.

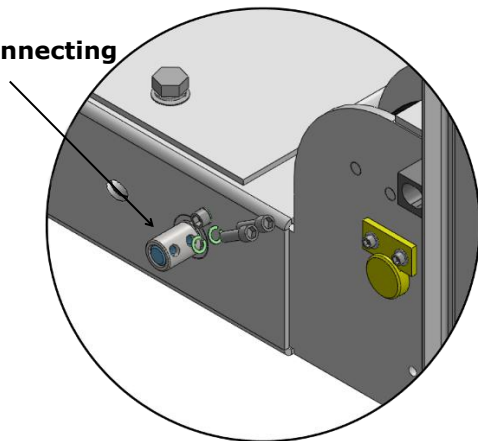

Fig. 24

View B

Install extend lock release handle and plastic ball

According to the above diagram, fix safety lock connecting bar and safety lock connecting assy. by M8*35 bolts and washers on cross beam B.

K. Install power unit and connecting tube(See Fig.25)

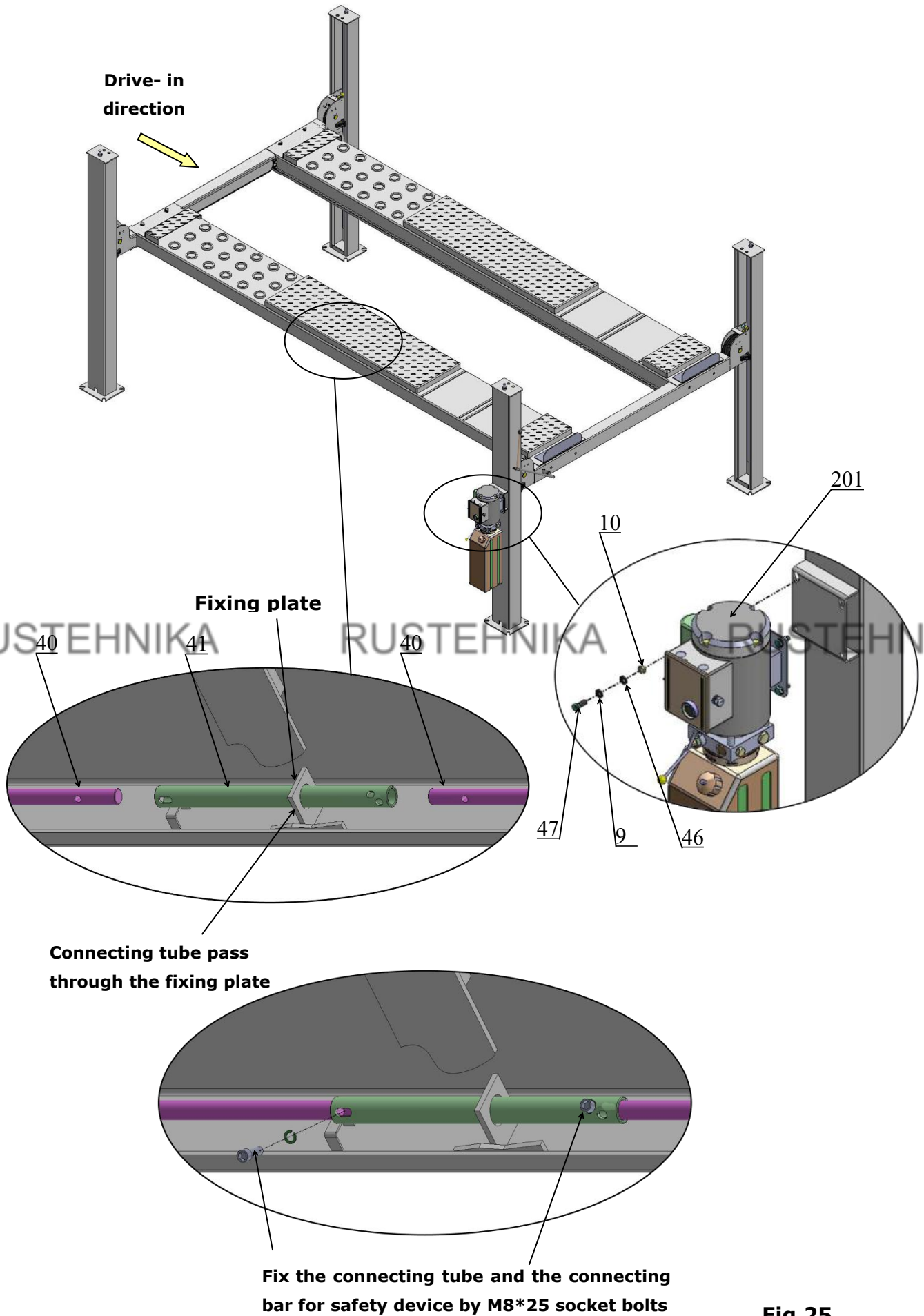

Fig.25

L. Install power unit (See Fig.26)

Note: Oil hoses connected to oil cylinder must be passed above the cable and oil inlet port should be inclined upwards to avoid the oil hose scratched by cable.

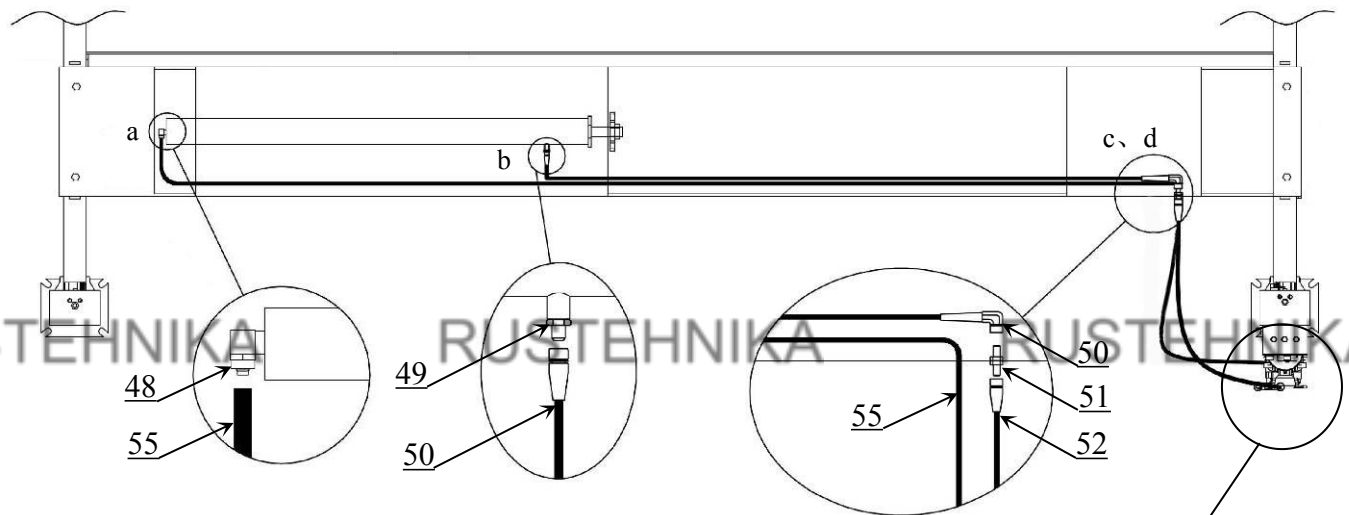
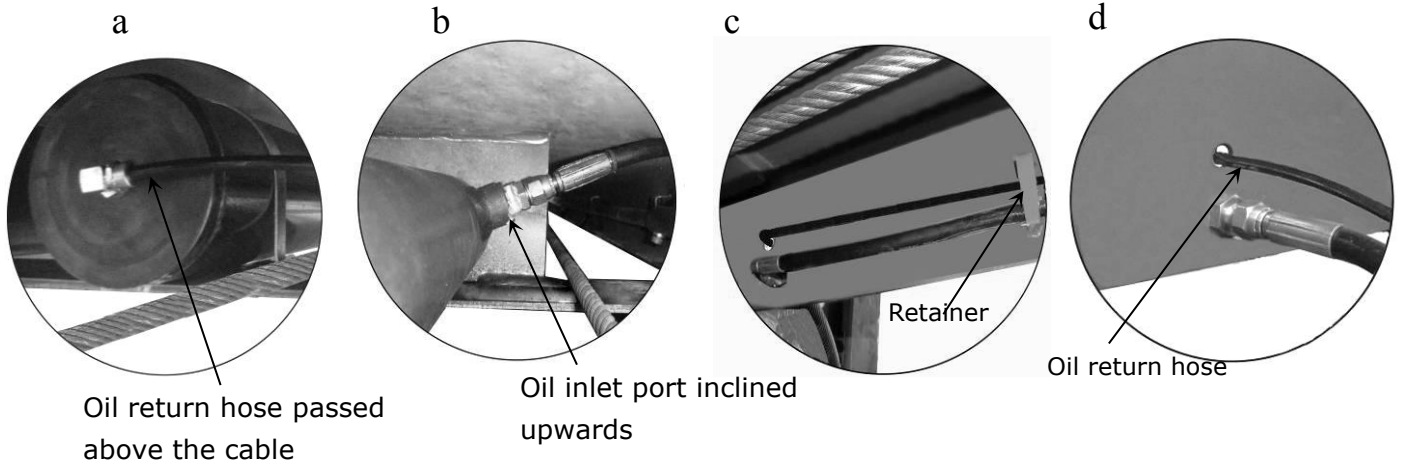
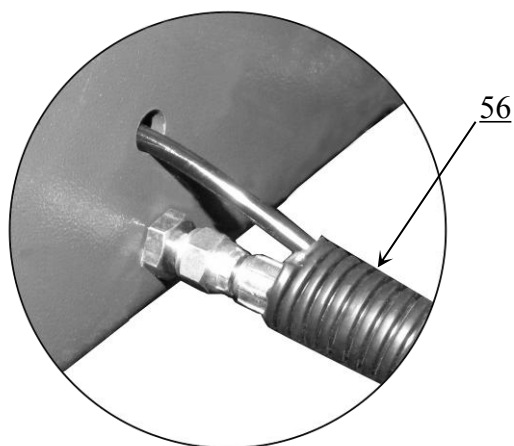
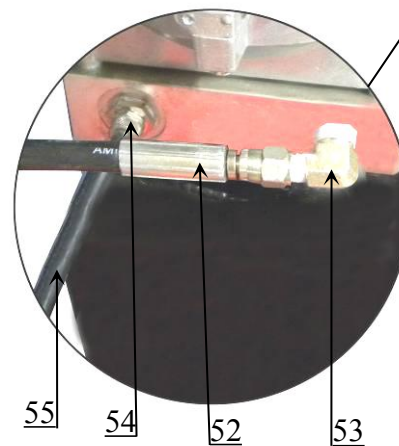

Fig.26



The oil hose and oil return hose pass through the protective hose and connect to the power unit



M. Install Electrical System

Connect the power source according to the data plate of Power Unit.

Note: For the safety of operators, the power wiring must contact the floor well.

PEAK Single phase motor (See Fig.27).

1. Connecting the two power supply lines (fire wire **L** and zero wire **N**) to terminals of AC contactor marked **L1, L2** respectively.
2. Connecting the two motor wires to terminals of AC contactor marked **T1, T2**.
3. Connecting **A2** to **L2** of AC contactor.
4. Connect the two wires of the button switch to the terminals of AC contactor marked **A1, L1**.

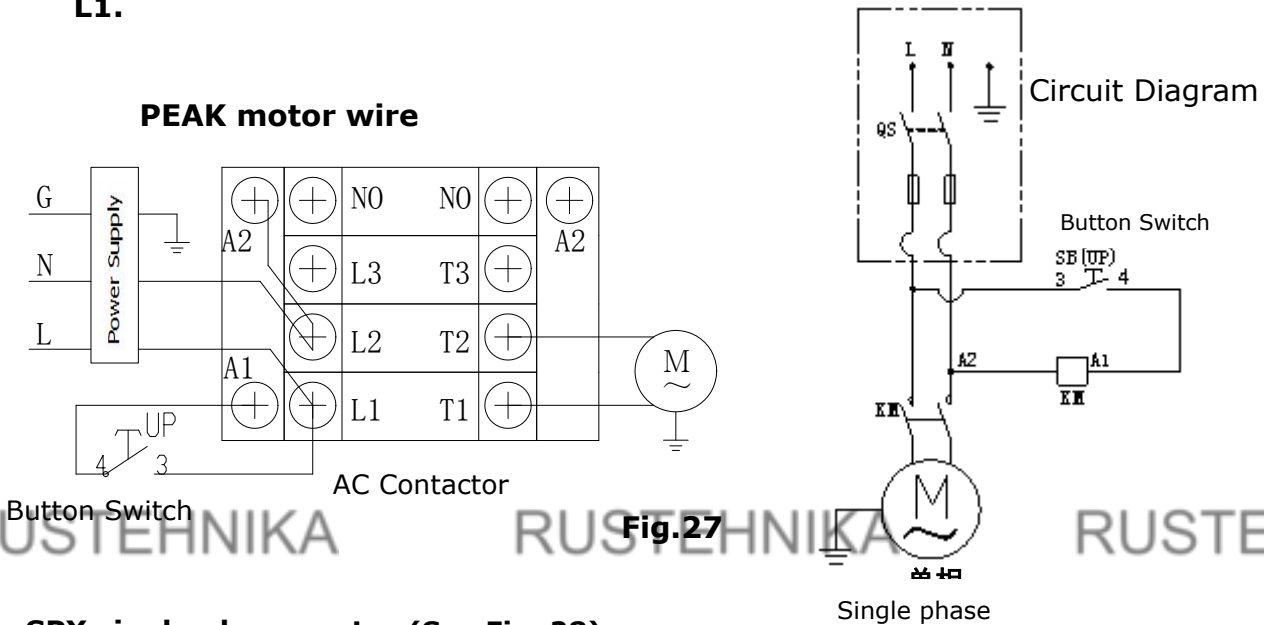

SPX single phase motor (See Fig. 28)

1. Power supply line (active wire **L**) is connected with wire **4#** of button switch.
2. Wire **3#** of button switch is connected with wire **6#** of motor.
3. Wire **5#** of motor is connected with zero wire **N** of power supply.

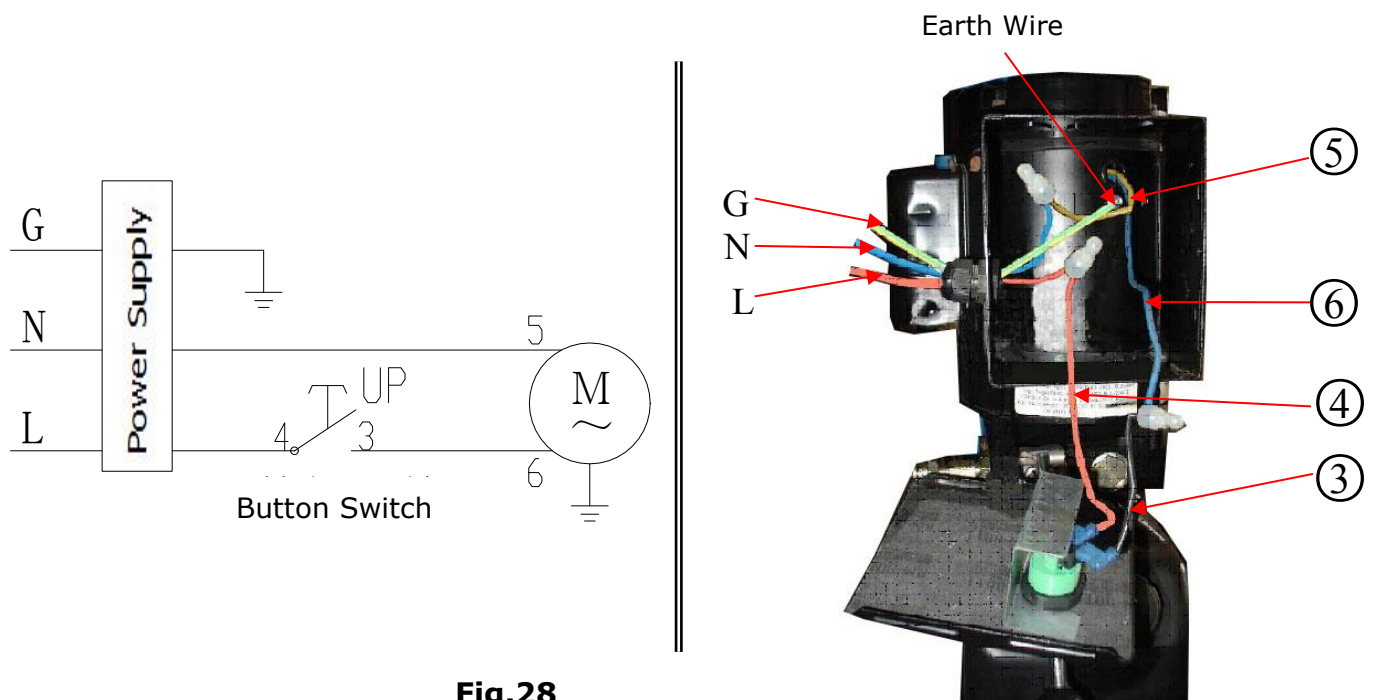

1. Circuit Diagram (See Fig. 29)

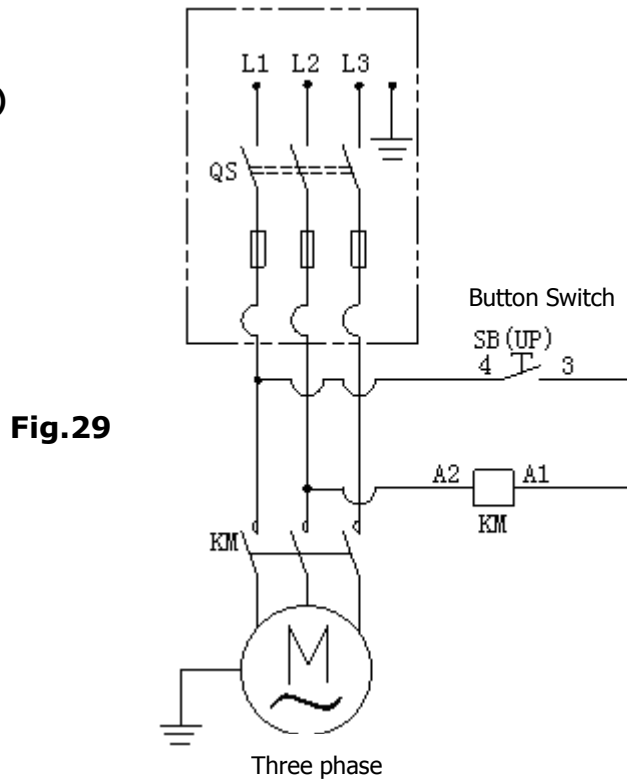

2. Connection Step (See Fig. 30)

- a. The power source wires (**L1, L2, L3**) are connected with terminals of AC contactor marked **L1, L2, L3** respectively.
- b. The three wires of motor are connected with terminals of AC contactor marked **T1, T2, T3** respectively.
- c. Terminal **4#** of control button is connected with terminals of AC contactor marked **L1**; Wire **3#** of control button is connected with **A1** terminals.

Circuit Diagram
Fig. 30

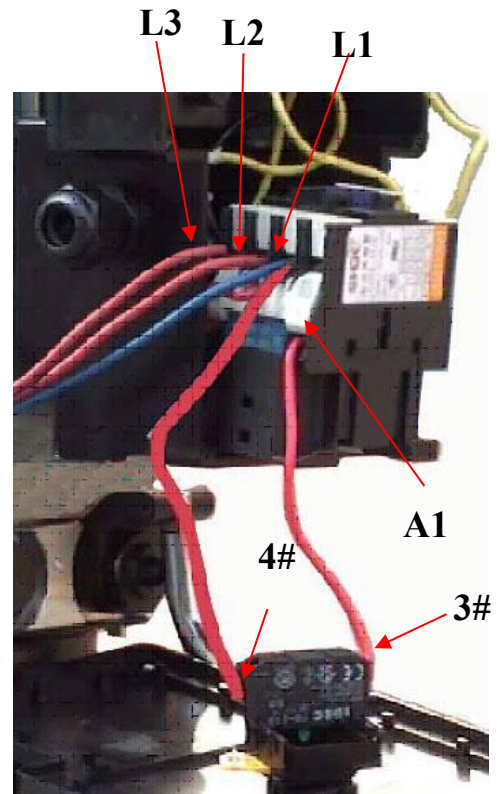
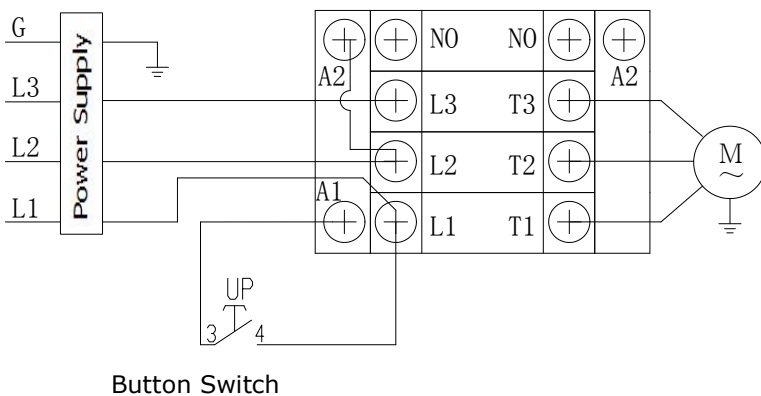

N. Install spring and safety cover of cross beam (See Fig. 31).

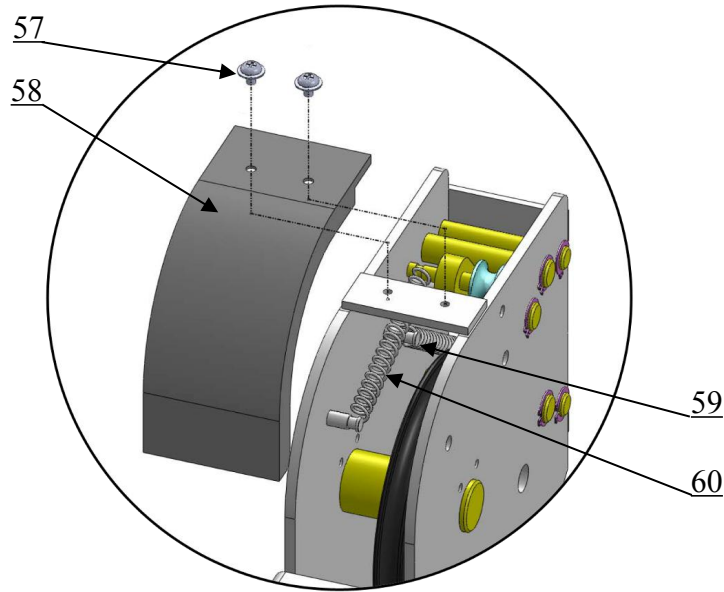

Fig. 31

O. Install the drive-in ramp, steel ball set, slip plate, pin for slip plate, cover for adjustable turnplate. (See Fig.32)

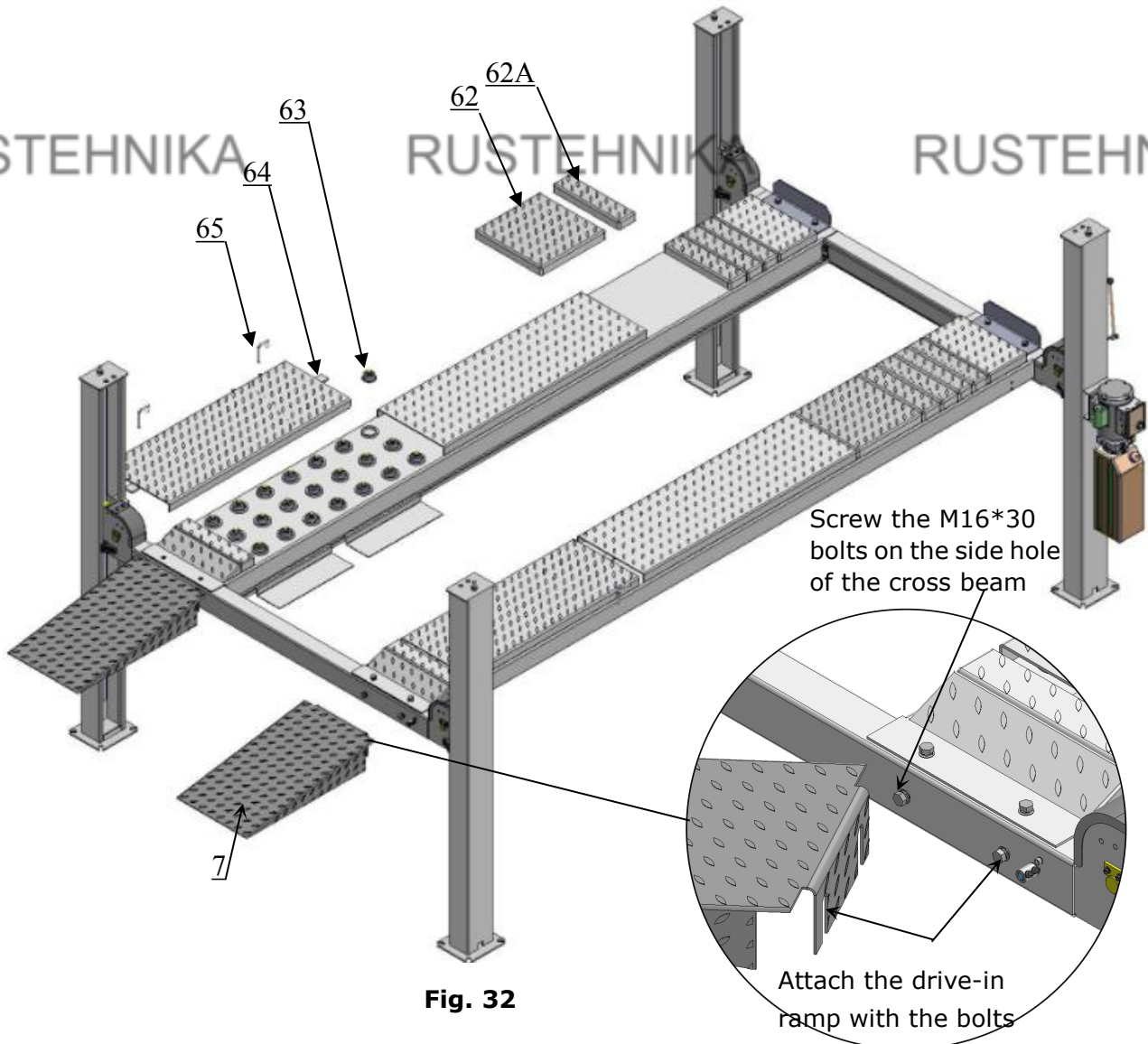
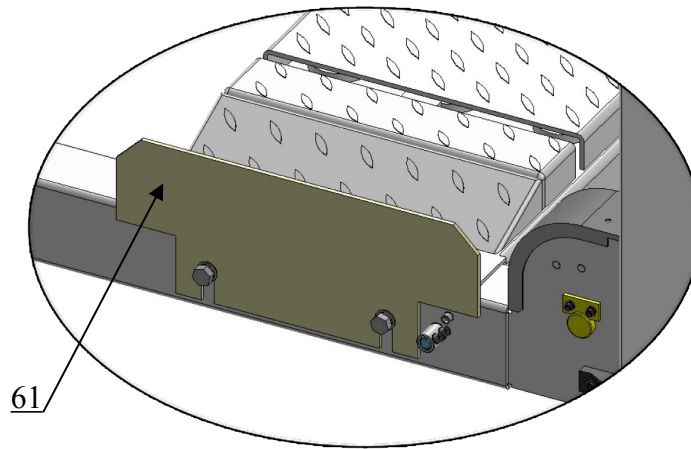

Fig. 32

P. Install Rear wheel stop plates (See Fig. 33)

After driving the vehicle on the lift, take off the drive-in ramp, install rear wheel stop plates to the drive-in ramp position.

**Fig. 33****Q. Install Layer Board Assy. for Drive in Ramp**

Take down the Drive in Ramp, and put it between the platforms and on top of layer board assy. (See Fig. 34)

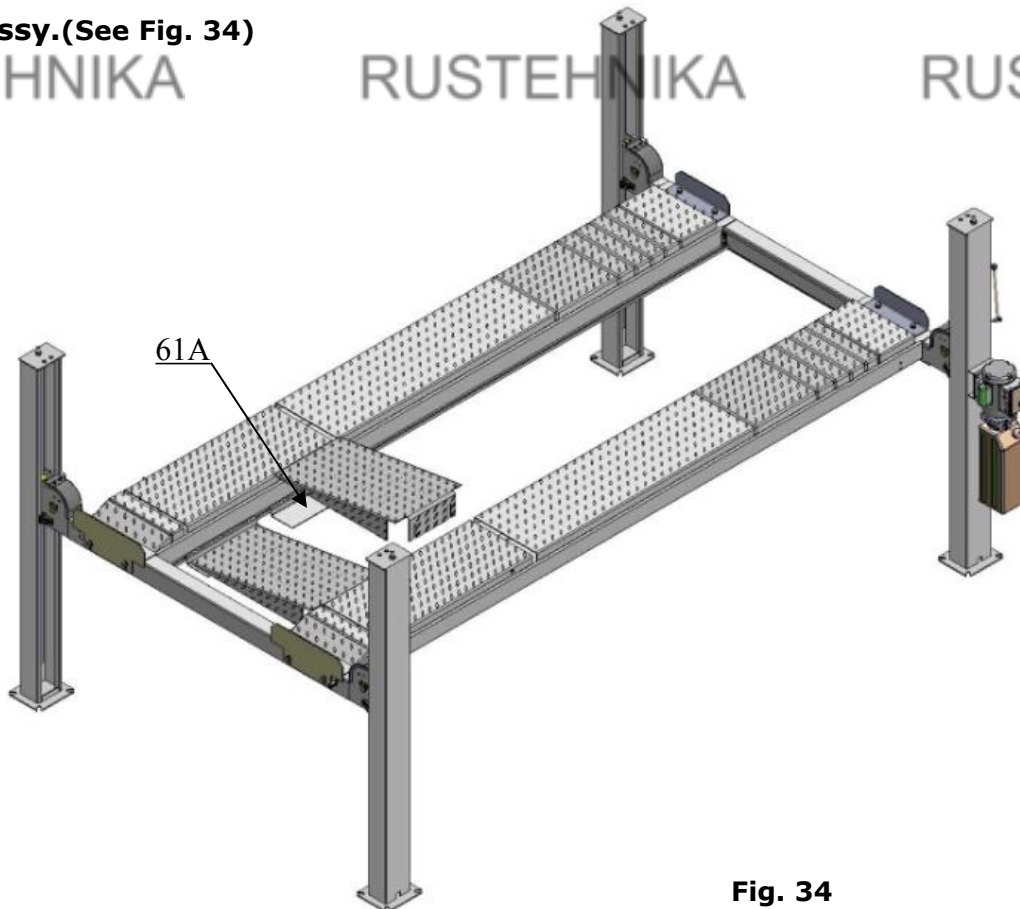
**Fig. 34**

IV. EXPLODED VIEW

Model: KHL-4000A

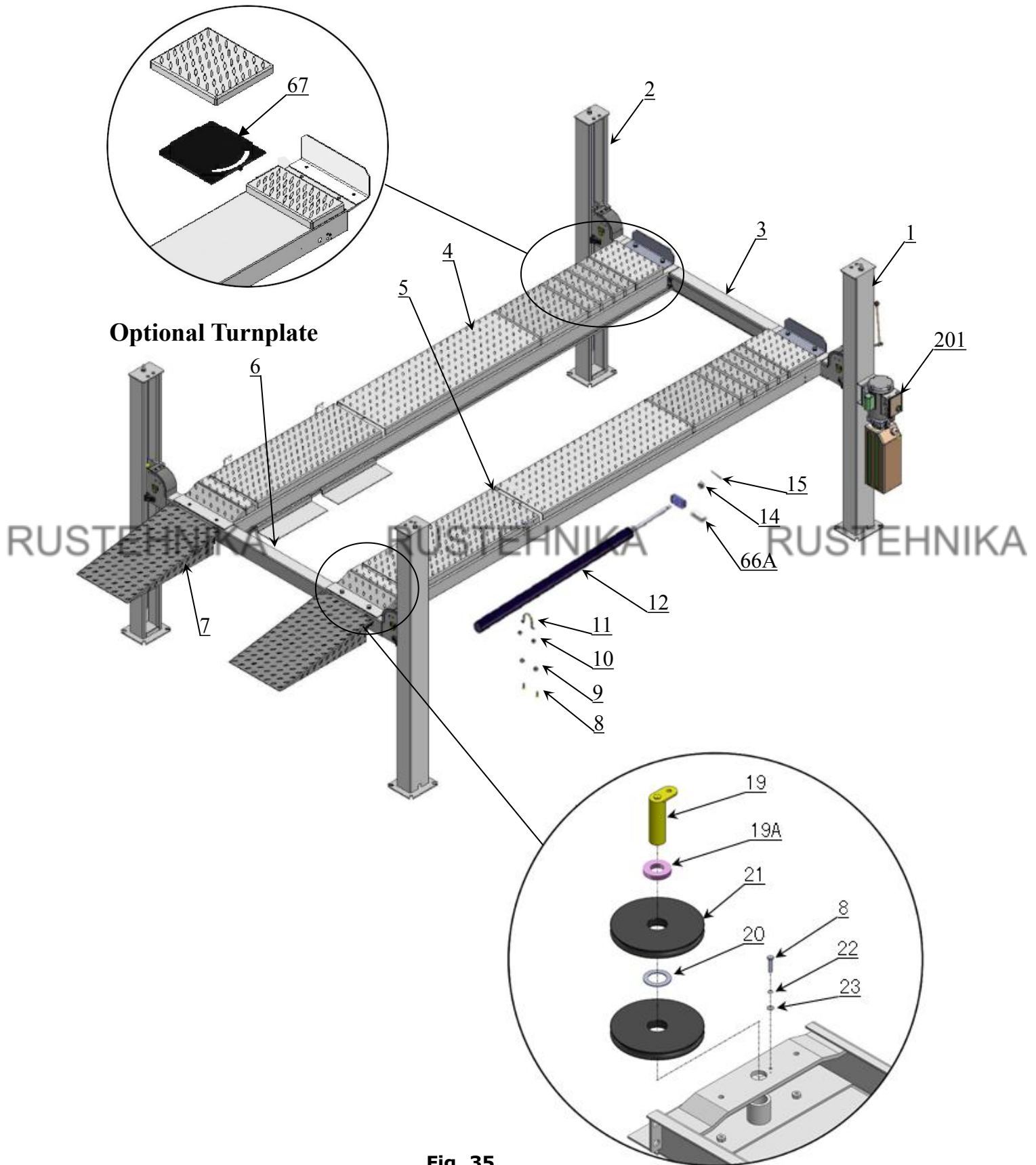

Fig. 35

CROSS BEAM

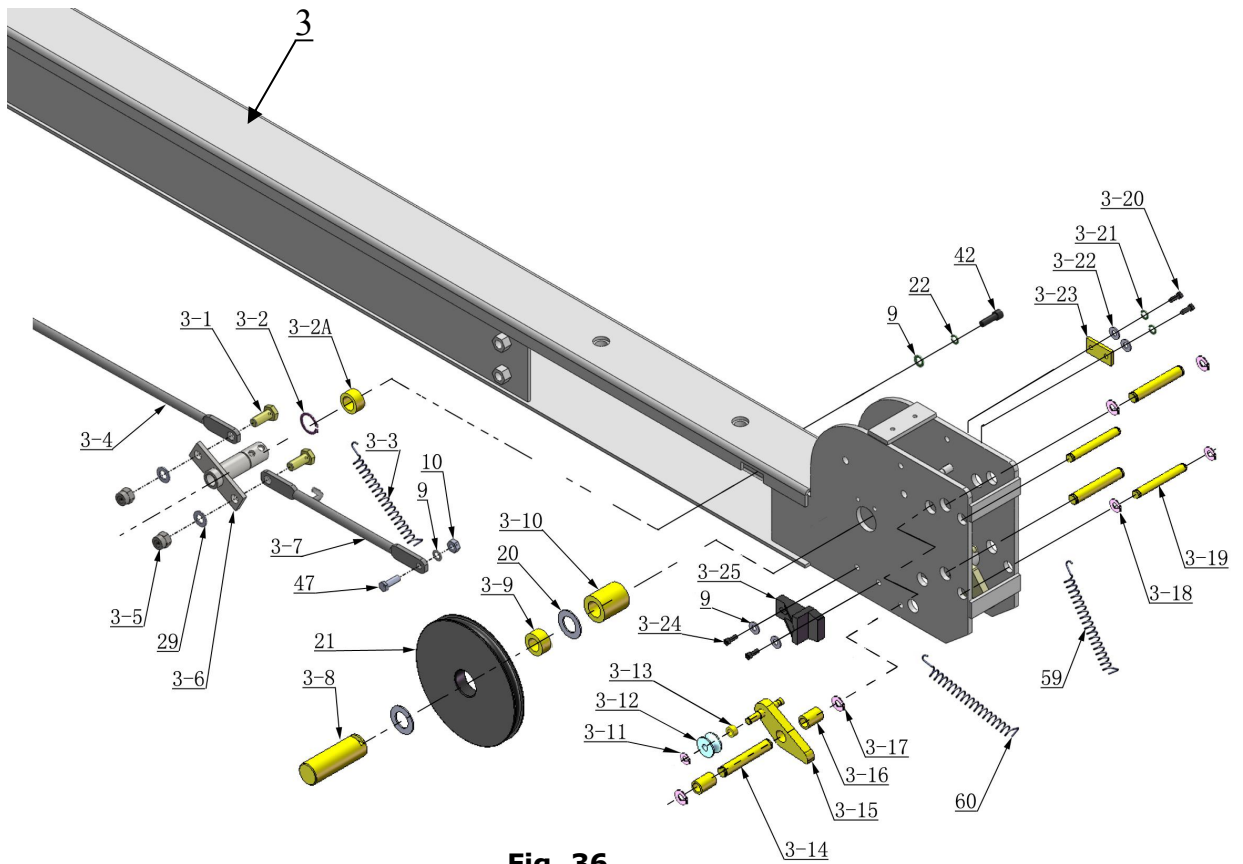

Fig. 36

CYLINDERS

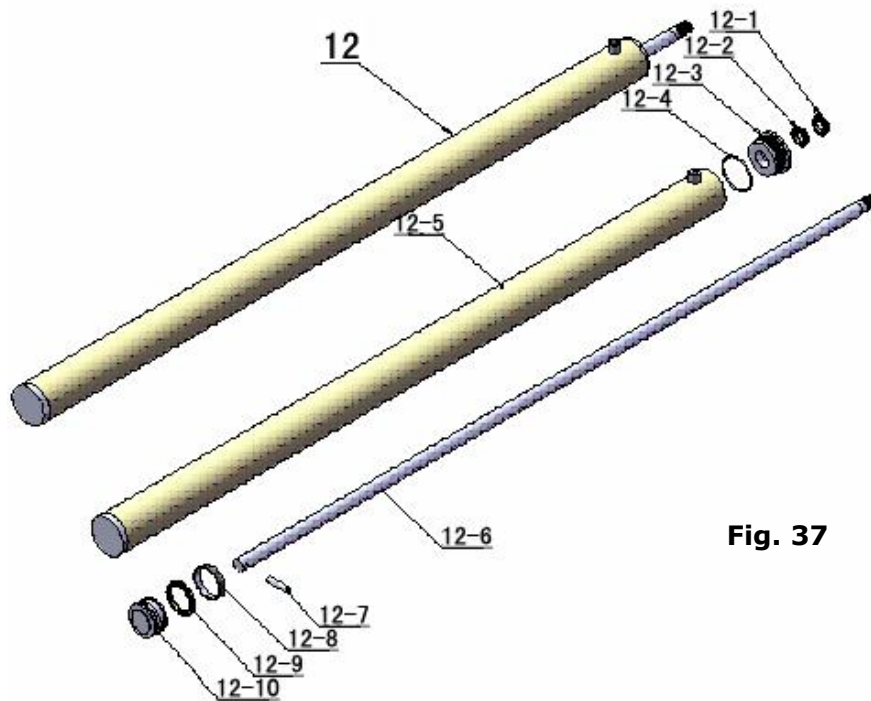

Fig. 37

SPX Manual power unit 220V/50HZ, Single phase

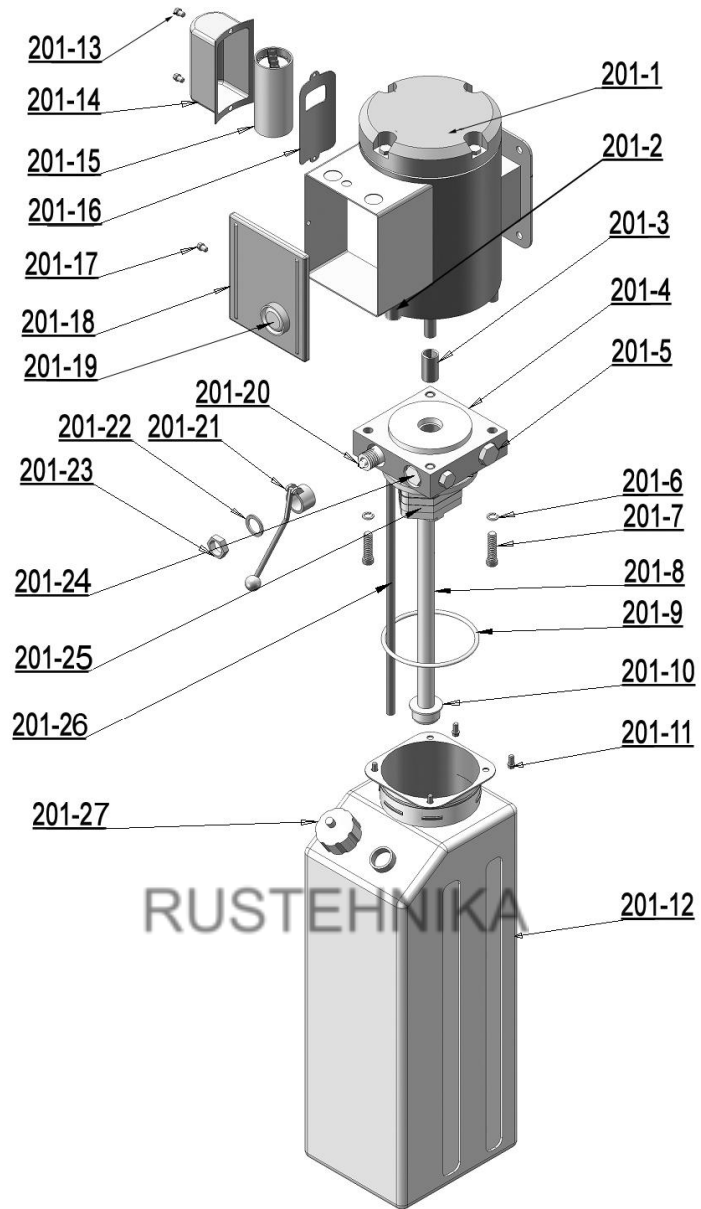

Fig. 38

PEAK Manual power unit

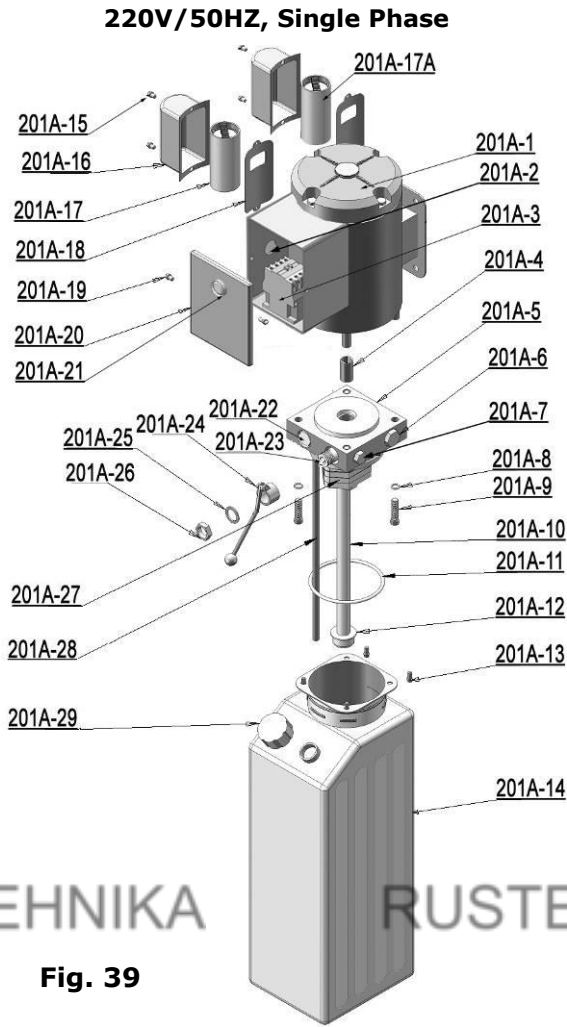

Fig. 39

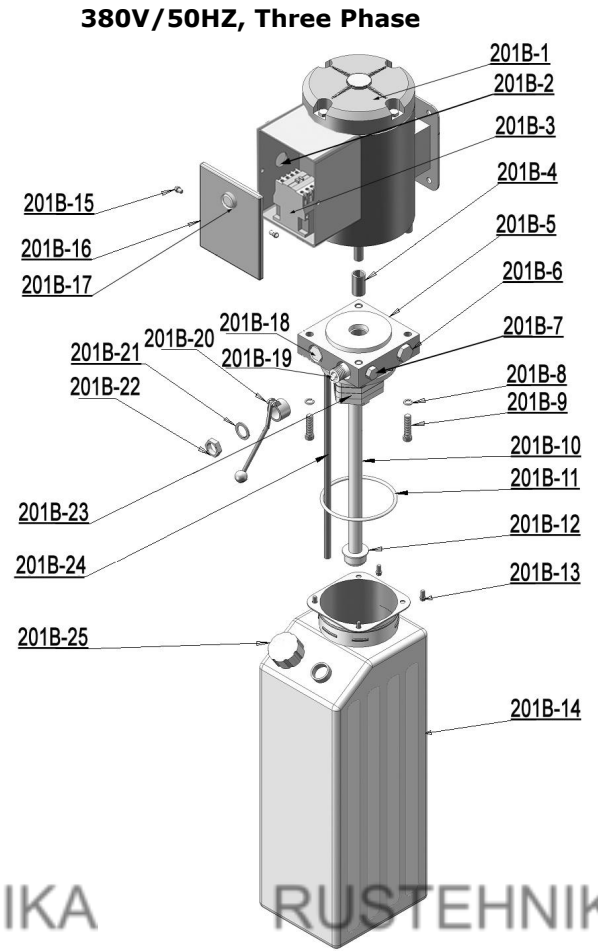

Fig. 40

Illustration of hydraulic valve for SPX & PEAK hydraulic power unit

a. SPX manual power unit, 220V/50HZ, Single phase (See Fig. 41)



Fig. 41

b. PEAK manual power unit, 220V/50HZ, Single phase (See Fig. 42)

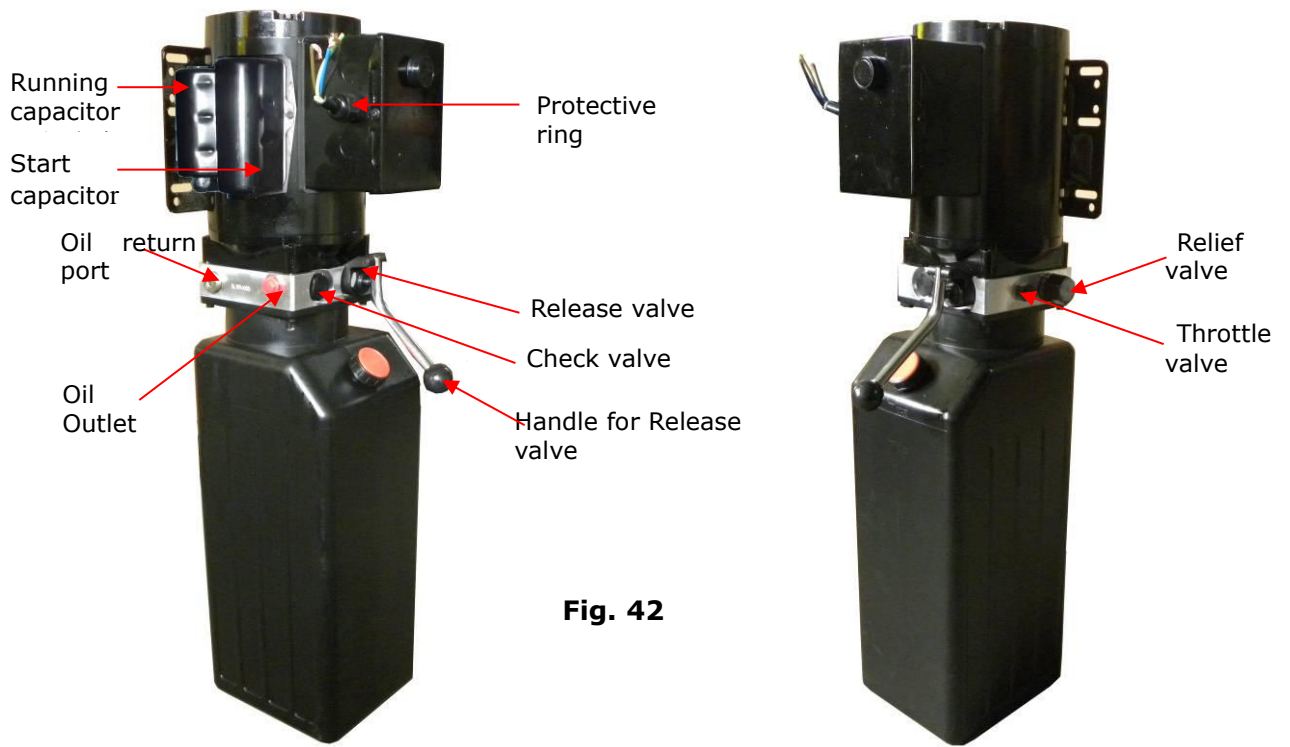

Fig. 42

C. PEAK manual power unit, 380V/50HZ, Three phase (See Fig. 43)

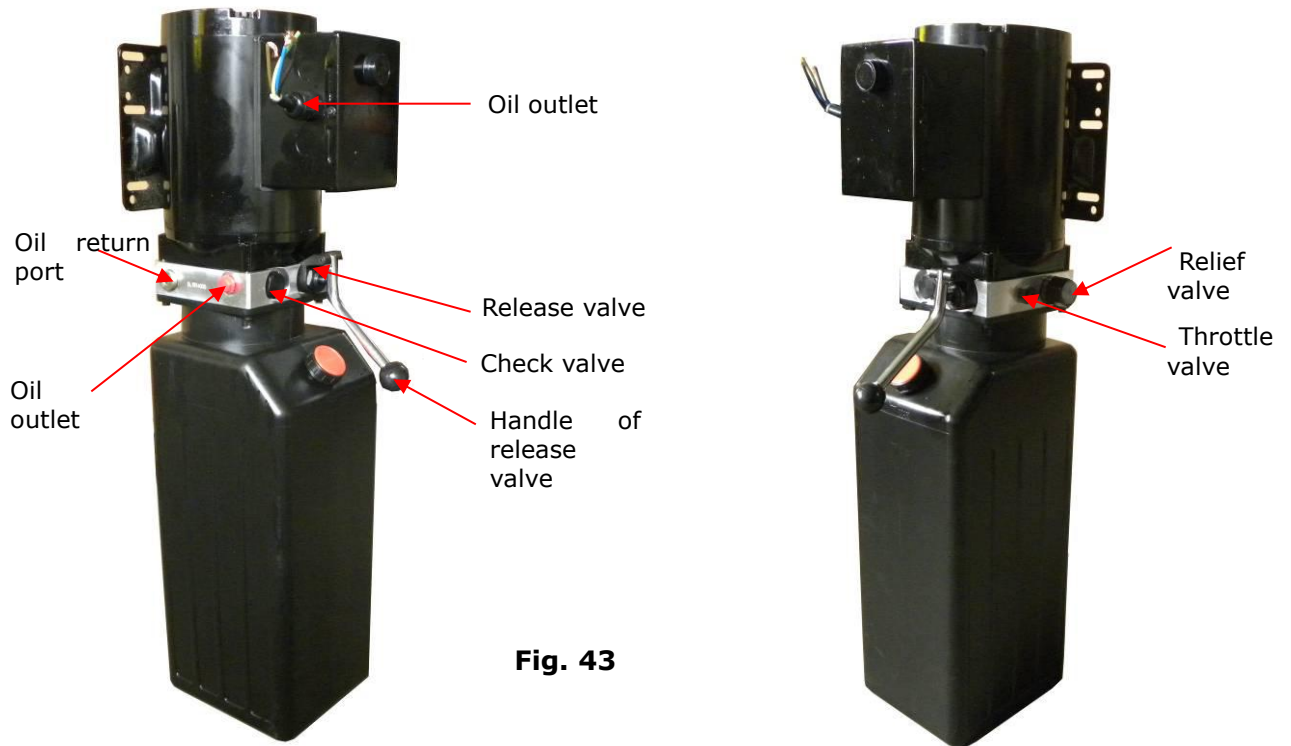
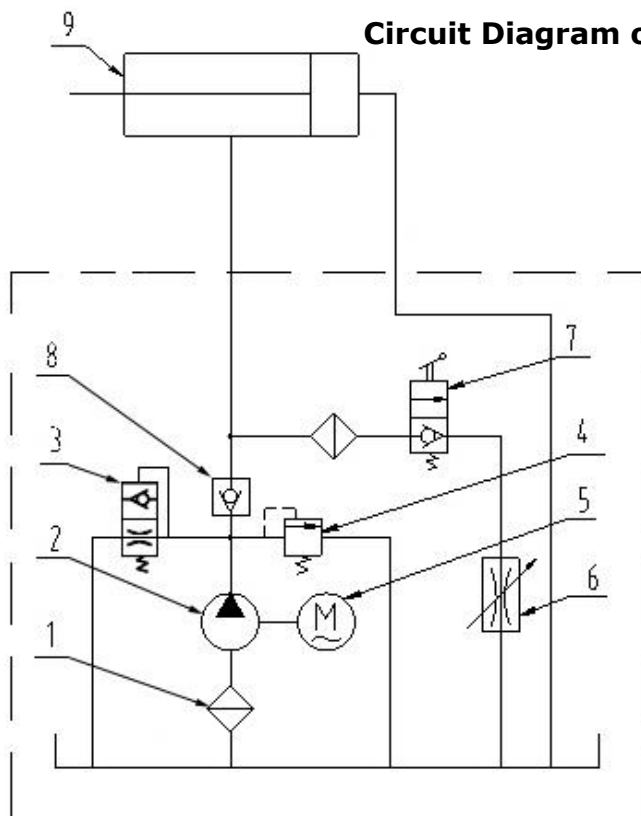

Fig. 43

V. TEST RUN

1. Fill the reservoir with approximately 12L Hydraulic Oil (**Note:** In consideration of Power Unit's durability, please use **Hydraulic Oil 46#**).
2. Press the control button till the cables are strained. Check the cables and confirm they are in the proper pulley position. Make sure the cables are not across.
3. Press the release valve handle and the cross-beam is engaged to the safety ladders, and then adjust the platforms to be level by adjusting the nuts of safety ladders. Tighten the nuts above and under the safety ladder top plate after leveling.
4. Adjust the cable fitting hex nuts to make platforms and four safety locks work synchronously. You need to run the lift up and down for several times, meanwhile do the synchronous adjustment till the four safety devices can lock and release at the same time.
5. Adjust the clearance between the column and the sliding block of cross-beam to about 2mm, and tighten the bolts of the sliding block.
6. After finishing the above adjustment, test running the lift with load. Run the lift with platforms in low position first, make sure the platforms can rise and lower synchronously and the safety device can lock and release synchronously. And then test run the lift to the top completely. If there are anything improper, repeat the above adjustment.



NOTE

1. Filter
2. Gear pump
3. Cushion valve
4. Relief Valve
5. Motor
6. Throttle Valve
7. Release Valve
8. Check valve
9. Cylinder For Four-post lift

Fig. 44

VI. OPERATION INSTRUCTIONS

To lift vehicle

1. Keep clean of environment near the lift.
2. Drive vehicle to the platform and put on the brake.
3. Take off the drive-in ramp, install rear wheel stop plates to the drive-in ramp position.
4. Turn on the power and press the control button, raise the lift to the working position.

Note: make sure the vehicle is steady when the lift is raised.

5. Press the release valve handle to lock the lift on the safety ladder. Make sure the safety device is engaged at the same height before work.

To lower vehicle

1. Be sure the clearance of around and under the lift, only leaving operator in lift area.
2. Press the control button, the lift will be raised for 3-5 seconds, and then press the safety release handle, make sure the safety device released, press the release valve handle by the other hand, then the lift will be lowered automatically.
3. After the lift lower to lowest position, take off the rear stop plate, install the drive-in ramp and drive away the vehicle.

4. Turn off the power.

VII. MAINTENANCE SCHEDULE

Monthly:

1. Lubricate cable with lubricant;
2. Check all cable connection, bolts and pins to insure proper mounting;
3. Make a visual inspection of all hydraulic hoses/lines for possible wear or leakage;
4. Lubricate all rollers, safety devices with 90wt. gear oil or equivalent.

Every six months:

1. Make a visual inspection of all moving parts for possible wear, interference or damage.
2. Inspect and adjust the tension for cable accordingly to make sure the lift is level;
3. Check verticality of columns.

VIII. TROUBLE SHOOTING

TROUBLE	CAUSE	REMEDY
Motor does not run	<ol style="list-style-type: none"> 1. Button does not work 2. Wiring connections are not in good condition 3. Motor burned out 4. AC contactor burned out 	<ol style="list-style-type: none"> 1. Replace button 2. Repair all wiring connections 3. Repair or replace motor 4. Replace AC contactor
Motor runs but the lift is not raised	<ol style="list-style-type: none"> 1. Motor runs in reverse rotation 2. Release valve in damage 3. Gear pump in damage 4. Relief valve or check valve in damage 5. Low oil level 	<ol style="list-style-type: none"> 1. Reverse two power wire 2. Repair or replace 3. Repair or replace 4. Repair or replace 5. Fill tank
Lift does not stay up	<ol style="list-style-type: none"> 1. Release valve out of work 2. Relief valve or check valve leakage. 3. Cylinder or fittings leaks 	Repair or replace
Lift raises too slow	<ol style="list-style-type: none"> 1. Oil line is jammed 2. Motor running on low voltage 3. Oil mixed with Air 4. Pump leaks 5. Overload lifting 	<ol style="list-style-type: none"> 1. Clean the oil line 2. Check electrical system 3. Fill tank 4. Repair or replace pump 5. Check load
Lift cannot lower	<ol style="list-style-type: none"> 1. Safety device are not in activated 2. Release valve damaged 	<ol style="list-style-type: none"> 1. Operate again 2. Repair or replace

IX. PARTS LIST FOR MODEL KHL-4000A

Item	Part#	Description	Quantity	Remark
1	410129	Powerside Column	1	
2	410130	Offside Column	3	
3	410121	Cross Beam A	1	
4	410162	Offside Platform	1	
5	410161	Powerside Platform	1	
6	410122	Cross Beam B	1	
7	410007	Drive-in ramp	2	
8	209043	Hex Bolt	4	
9	209033	Washer	28	
10	209005	Self locking Nut	10	
11	410090	Cylinder Fixed Ring	1	
12	410081	Cylinder	1	
13	420013	Cylinder Connecting Plate	1	
14	420014	Hex Nut	1	
15	201005	Split Pin	1	
201	209002	Manual power unit	1	
17	420175A	Hex Nut	16	
18	410022	Safety Ladder	4	
19	420022A	Pulley Pin Assy.	2	
19A	410106	Washer	1	
20	420023A	Washer	12	
21	420024B	Pulley	10	
22	209034	Lock washer	10	
23	420144	Washer	2	
24	410013	Hex Bolt	8	
25	420137	Lock washer	8	
26	420029	Washer	8	
27	410014	Hex Bolt	4	
28	410116	Tire Stop Plate	2	
29	206006	Washer	12	
30	420026	Lock Washer	8	
31	410105	Hex Bolt	8	
32	209059	Anchor bolt	16	
33	410101	Shim(1mm)	20	
34	620065	Shim(2mm)	20	
35	410055	Cable ①	1	
36	410164	Cable ②	1	
37	410057	Cable ③	1	
38	410163	Cable ④	1	
39	420020B	Hex Bolt	4	
40	410159	Connecting Bar for safety device	2	
Item	Part#	Description	Note	Remark

41	410024	Connecting tube	1	
42	209032	Socket bolt M8*25	4	
43	217005	Plastic ball	1	
43A	209056	Self locking Nut	1	
44	410025	Socket bolt	4	
45	410026	Safety Release Handle	1	
45A	410100	Extension release handle assy.	1	
46	209004	Rubber ring	4	
47	209003	Hex Bolt	8	
48	420166	90° Fitting	1	
49	420119	Straight Fitting for Cylinder	1	
50	610068	Oil Hose	1	
51	420120	Extend straight fitting with nut	1	
52	207026	Oil hose	1	
53	209060	90° Fitting for power unit	1	
54	420095	Straight fitting	1	
55	410061	Oil return hose	1	
56	410036	Protective hose	1	
57	209145A	Cup head bolt with washer	8	
58	410029	Plastic cover for cross beam	4	
59	410030	Spring	4	
60	420033	Spring	4	
61	410094	Tire Stop Plate	2	
61A	410101	Layer Board Assy.	2	
62	430004	Plate for Adjustable Turnplate	2	
62A	480024	Turnplate block	8	
63	420157	Steel Ball Set	42	
64	430007	Slip Plate	2	
65	430006	Pin For Slip Plate	4	
66	410506	Parts box	1	
66A	420239	Limit Slider	1	
Optional Parts (See Fig.35)				
67	420158	Turnplate	4	
Parts For Cylinder (See Fig.37)				
12-1	420059	Dust Ring	1	
12-2	420060	Y- Ring	1	
12-3	410082	Head Cap	1	
12-4	410083	O- Ring	1	
12-5	410084	Bore Weldment	1	
12-6	420064	Piston Rod	1	
12-7	410085	Pin	1	
12-8	410086	Support Ring	1	
12-9	410087	Y- Ring	1	
12-10	410088	Piston	1	

Item	Part#	Description	Note	Remark
Parts For Cross Beam (See Fig.36)				
3-1	206024	Hex bolt	4	
3-2	206032	Snap Ring	2	
3-2A	217020	Bronze Bush	2	
3-3	410099	Spring	2	
3-4	410063	Connecting bar for safety lock	2	
3-5	206023	Self locking Nut	4	
3-6	410032	Safety lock rotated device assy.	2	
3-7	410064	Connecting bar assy. for safety lock	2	
3-8	420041A	Pulley Pin	4	
3-9	420132A	Pulley Bush	10	
3-10	420040A	Pulley pin sleeve	4	
3-11	209010	Snap ring	4	
3-12	420035	Tension pulley	4	
3-13	420174	Spacer	4	
3-14	420171	Pin	12	
3-15	420175	Slack-cable safety lock (Left & Right)	2/ea.	
3-16	420172	Pin Bush For Slack-cable safety lock	8	
3-17	206019	Snap ring	24	
3-18	420037	Snap ring	16	
3-19	420038	Pin	8	
3-20	420138	Socket Bolt	8	
3-21	209149	Lock washer	8	
3-22	420045	Washer	8	
3-23	420044	Stop block	4	
3-24	420043	Socket bolt	16	
3-25	420042	Slider	8	
Parts For SPX Manual Power Unit 220V/50HZ/1 Phase (See Fig.38)				
201-1	81400030	Motor	1	
201-2	81400159	Protective Ring	1	
201-3	81400063	Motor Connecting Shaft	1	
201-4	81400031	Valve Body	1	
201-5	81400160	Relief Valve	1	
201-6	81400161	Lock Washer	4	
201-7	81400162	Socket Bolt	4	
201-8	81400121	Inlet Pipe	1	
201-9	81400163	O-Ring	1	
201-10	81400164	Filter	1	
201-11	81400165	Hex bolt	4	
201-12	81400093	Reservoir	1	
201-13	81400166	Cross screw	2	

Item	Part#	Description	Note	Remark
201-14	81400167	Cover of Capacitor	1	
201-15	81400087	Capacitor	1	
201-16	81400168	Rubber Gasket	1	
201-17	81400169	Hex Bolt	1	
201-18	81400062	Cover of Motor Terminal Box	1	
201-19	81400028	Push Button	1	
201-20	81400105	Release Valve	1	
201-21	81400033	Handle For Release Valve	1	
201-22	81400170	Washer	1	
201-23	81400171	Hex Nut	1	
201-24	81400043	Check Valve	1	
201-25	81400123	Gear Pump	1	
201-26	81400122	Oil Return Pipe	1	
201-27	81400172	Filler Cap	1	
Parts For PEAK Manual Power Unit 220V/50HZ/1 Phase (See Fig.39)				
201A-1	81400048	Motor	1	
201A-2	81400178	Protective Ring	1	
201A-3	81400179	AC Contactor	1	
201A-4	81400127	Motor Connecting Shaft	1	
201A-5	81400067	Valve Body	1	
201A-6	81400106	Relief Valve	1	
201A-7	81400107	Throttle Valve	1	
201A-8	209149	Lock Washer	4	
201A-9	81400148	Socket Bolt	4	
201A-10	81400134	Inlet Pipe	1	
201A-11	81400144	O-Ring	1	
201A-12	81400150	Filter	1	
201A-13	81400145	Socket Bolt	4	
201A-14	81400024	Reservoir	1	
201A-15	420148	Cup Head Bolt With Washer	4	
201A-16	81400066	Cover of Capacitor	2	
201A-17	81400130	Start Capacitor	1	
201A-17A	81400088	Run Capacitor	1	
201A-18	81400180	Rubber Gasket	2	
201A-19	420148	Cup Head Bolt With Washer	2	
201A-20	81400050	Cover of Motor Terminal Box	1	
201A-21	81400045	Push Button	1	
201A-22	81400044	Check Valve	1	
201A-23	81400075	Release Valve	1	
201A-24	81400117	Handle For Release Valve	1	
201A-25	81400181	Washer	1	
201A-26	81400182	Hex Nut	1	
201A-27	81400041	Gear Pump	1	

Item	Part#	Description	Note	Remark
201A-28	81400084	Oil Return Pipe	1	
201A-29	81400113	Filler Cap	1	
Parts For PEAK Manual Power Unit 380V/50HZ/3 Phase (See Fig.40)				
201B-1	81400183	Motor	1	
201B-2	81400178	Protective Ring	1	
201B-3	81400184	AC Contactor	1	
201B-4	81400127	Motor Connecting Shaft	1	
201B-5	81400177	Valve Body	1	
201B-6	81400175	Relief Valve	1	
201B-7	81400107	Throttle Valve	1	
201B-8	209149	Lock Washer	4	
201B-9	81400148	Socket Bolt	4	
201B-10	81400134	Inlet Pipe	1	
201B-11	81400144	O-Ring	1	
201B-12	81400150	Filter	1	
201B-13	81400145	Socket Bolt	4	
201B-14	81400024	Reservoir	1	
201B-15	420148	Cup Head Bolt With Washer	2	
201B-16	81400050	Cover of Motor Terminal Box	1	
201B-17	81400045	Push Button	1	
201B-18	81400044	Check Valve	1	
201B-19	81400075	Release Valve	1	
201B-20	81400117	Handle For Release Valve	1	
201B-21	81400181	Washer	1	
201B-22	81400182	Hex Nut	1	
201B-23	81400041	Gear Pump	1	
201B-24	81400084	Oil Return Pipe	1	
201B-25	81400113	Filler Cap	1	

RUSTEHNKA

RUSTEHNKA

RUSTEHNKA



RUSTEHNKA

RUSTEHNKA

RUSTEHNKA

PEAK CORPORATION

A2-A3 Xingui Industrial Area, Yanbu, Nanhai District,
Foshan(528247), China

Tel: 86-757-81102815 81102805

Fax: 86-757-81102809

Email: peak@peaklift.cn <http://www.peaklift.cn>

Manual Part NO.: **72143202**

Revision Date: **03/2017**

RUSTEHNKA

RUSTEHNKA

RUSTEHNKA