



Rustehnika.ru

Rustehnika.ru

Rustehnika.ru



Smontagomme automatico con tecnologia "leva la leva"

Il primo e l'originale dal 2001, l'unico senza contatto col cerchio.



Automatic tyre changer with "Leva la leva" (Without lever) technology

The first and original since 2001, the only without contact with the rim.

ARTIGLIO MASTER 26 MI



Rustehnika.ru

Rustehnika.ru

Rustehnika.ru

Con Artiglio Master è finita l'era della leva, della fatica fisica, dei patemi per i cerchi più delicati, delle pericolose tensioni sul pneumatico e dell'angoscia nel trattare cerchi mai visti ed in continua evoluzione. **Innovativo e ineguagliato il principio di funzionamento** alla base di questa rivoluzione: preselezione elettronica del diametro della ruota con posizionamento automatico di tutti gli utensili, gruppo stallonatore con penetrazione controllata e comando automatico, testina porta utensili comandata automaticamente per **montare e smontare il pneumatico senza leva**; il tutto senza che l'operatore debba spostarsi dalla posizione di lavoro, essendo tutti i comandi riuniti in una consolle ergonomica che permette di lavorare in **completa sicurezza, con la massima precisione e ottimizzando al meglio i tempi**. Inoltre grazie alle nuove motorizzazioni a motoinverter "MI POWERED SYSTEM" il numero dei giri dell'autocentrante sotto sforzo si adegua per **mantenere costante la coppia, con vantaggi evidenti soprattutto su ruote Low Profile e Run Flats**. La selezione automatica della velocità in base allo sforzo richiesto dalla macchina significa **facilità di intervento anche su ruote tradizionalmente difficili, ottimizzazione dei tempi di lavoro e risparmio energetico rispetto ai motori convenzionali**. Abbiamo migliorato quello che gli altri ancora inseguono.

*The Artiglio Master **ends the age of levers**, physical effort, worries about the delicate rims and dangerous stresses on tyres, and the headache of constantly having to deal with new rims in a fast-evolving sector. **The operating principle underlying this revolution is absolutely innovative and unique:** electronic presetting of the wheel diameter followed by automatic positioning of all the tools, the lift that loads and unloads the wheel in the optimal position, automatically operated bead breaker unit with controlled penetration, the automatically operated tool head that **mounts and demounts the tyres without a lever in sight**; and all this without the operator having to move from the working position, since all the controls are placed together on an ergonomic console that allows operation **in complete safety, ensuring maximum accuracy and optimizing the times**. Furthermore, thanks to the new "MI POWERED SYSTEM" built-in inverter motors, the number of turns of the turntable under stress adjusts so as to keep the torque constant, with great benefits in particular for Low Profile and Run Flat tyres. The automatic speed selection according to the effort required by the machine means ease of intervention even on traditionally difficult tyres, as well as working time optimisation and energy saving compared to conventional motors. We have improved what the others are still trying to achieve.*

1 Display che permette di impostare elettronicamente il diametro del cerchio con posizionamento di tutti gli utensili di lavoro, di leggere la pressione all'interno della ruota durante il ciclo di gonfiaggio e di selezionare la procedura di lavoro con sistema PAX. **1** Display allowing electronic setting of the rim diameter with positioning of all working tools, reading of the pressure inside the tyre during the inflation cycle, and selection of the PAX system working procedure.



2 Consolle di comandi suddivisa in tre distinte aree di lavoro che rende più immediato il riconoscimento dei movimenti e facilita l'uso da parte dell'operatore. **2** Control console subdivided into three separate working areas, for more immediate movement recognition, and easier use by the operator.

3 Il posizionamento degli utensili di montaggio/smontaggio e dei dischi stallonatori è gestito elettronicamente dalla macchina in base al diametro del cerchio, per garantire in ogni situazione le distanze ottimali di lavoro.

3 The mounting/dismounting tools and bead breaker disk positioning is electronically managed by the machine according to the rim diameter, so as to ensure optimal working distances in any situation.

*distanza ottimale - optimal distance



Rustehnika.ru

Rustehnika.ru

Rustehnika.ru



4 Sollevatore a comando pneumatico integrato che permette un facile posizionamento della ruota sull'autocentrante senza alcun tipo di sforzo da parte dell'operatore. (Brevetto Corghi)

4 Integrated pneumatically operated wheel lift for easy positioning of the wheel on the turntable with absolutely no operator effort. (Corghi Patent)



5 Nuovo sistema di bloccaggio ruote più rapido e universale. **5** New, even quicker and more universal wheel clamping system.





Movimento di stallonatura a penetrazione controllata - *Controlled penetration bead breaking movement*



Rustehnika.ru

Rustehnika.ru

Rustehnika.ru

- Ricerca automatica del tallone del pneumatico senza alcun contatto con il cerchio indipendentemente dalla sua forma.
- *Automatic location of the tyre bead, with no contact with the rim itself, regardless of its shape.*



- Smontaggio del tallone superiore. Il movimento d'arretramento in contemporanea dell'utensile e dell'autocentrante che blocca il cerchio, garantisce la corretta tolleranza di lavoro tra i due e riduce la tensione sul tallone del pneumatico.

- *Demounting the top bead. The simultaneous retraction of the tool and the turntable which clamps the rim, ensures the correct working tolerance between the two parts, and minimises the stress on the tyre bead.*

Montaggio del tallone superiore - *Mounting the upper bead*



• Con morsetto basculante (accessorio a richiesta) • *With mobile clamp (optional accessory)*



• Con pinza • *With clamp*



• Con premitallone (accessorio a richiesta)
• *With bead pressing clamp (optional accessory)*



• L'utilizzo in contemporanea dei due bracci stallonatori permette una fasatura del pneumatico sul cerchio (ottimizzazione) riducendo gli squilibri in gioco e ove sia possibile permette la stallonatura simultanea dei due talloni. (con pneumatici da almeno 6" di larghezza)

• *Simultaneous use of the two bead breaker arms allows adjustment of the tyre position on the rim (optimisation), reducing unbalances, and allowing both beads to be broken at the same time where possible. (with tyres at least 6" wide)*

ACCESSORI IN DOTAZIONE - *STANDARD ACCESSORIES*



Accessori optional consigliati - Recommended optional accessories

cod. 801263408

- Premi tallone pneumatico
- *Pneumatic bead pressing tool*



cod. 0-51100502

- TPM-02 Dispositivo per il controllo dei sensori
- *TPM-02 Device for sensor checking*



cod. 8-11100037

- Kit cerchi furgone
- *Van rim kit*



cod. 8-11100038

- Flangia universale per cerchi ciechi
- *Universal closed rim flange*

Rustehnika.ru



cod. 8-11100039

- Flangia per ruote a canale rovescio
- *Reverse rim wheel flange*

Rustehnika.ru



cod. 801260961

- Kit intallonamento rapido: TI system
- *TI system kit*

Rustehnika.ru



- Dispositivo di gonfiaggio elettronico INFLATRON (ordinabile solo con la macchina)
- *Electronic inflating device INFLATRON (available with the machine only)*

Configurazione generale PAX - General setup for PAX tyres

Con supporto morbido - With soft support :



- Inserimento della “reglette”(protezione del cerchio) nel pneumatico PAX
- Insertion of the “réglette” (rim protection) on PAX tyres



- Stallonatura del tallone inferiore del pneumatico PAX e del suo supporto interno
- Breaking of bottom bead of PAX tyres and the internal rest

Configurazione generale SR - General setup for SR

Con supporto rigido - With rigid support :

 Support Ring **BRIDGESTONE**

 Support Ring **Continental**

 Support Ring **YOKOHAMA**



DATI TECNICI**TECHNICAL DATA**

range dimensioni ruota	wheel dimension range	
diametro cerchio	rim diameter	12" ÷ 26"
diametro max pneumatico	maximum tyre diameter	1100 mm (*)
larghezza massima pneumatico	maximum tyre width	360 mm (14")
pneumatici trattabili	tyre types processed	convenzionali, low profile e Run Flat conventional, low profile and Run Flat
autocentrante	turntable	
bloccaggio	clamping	automatico - automatic
motorizzazione	drive system	motoinverter 2 velocità - 2 speed motoinverter
coppia di rotazione	rotation torque	1100 Nm
velocità di rotazione	rotation speed	7 - 18 rpm
stallonatore	bead breaker	
campo massimo di stallonatura	maximum bead breaking range	18"
corsa stallonatore	bead breaker stroke	450 mm
forza stallonatore	bead breaker force	7600 N
carico / scarico ruota	wheel loading / unloading	
azionamento	operation	pneumatico - pneumatic
peso max ruota	max wheel weight	65 Kg
alimentazione	power supply	
elettrica 1Ph	electric 1Ph	230V - 0,98 kW 50 Hz
elettrica 1Ph (alternativa)	electric 1Ph (alternative)	110V - 0,98 kW 60 Hz
pneumatica di esercizio	pneumatic operating pressure	8 ÷ 9,5 bar (minima - minimum)
peso	weight	450 kg (versione - version T.I. 465 kg)

*variabile con il variare della dimensione del cerchio - it changes according to rim size

Questo prodotto è stato omologato da:
This product has been certified by:

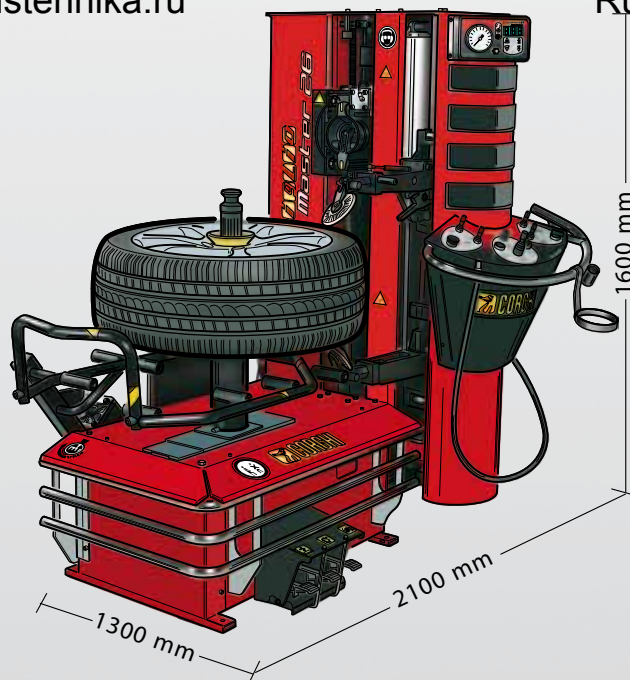

<http://www.facebook.com/CORGHIsPa>

<https://twitter.com/corghispa>

<http://www.youtube.com/CORGHIsPa>



Per aiutare il pianeta ottimizzando il consumo di carta, i nostri cataloghi sono consultabili sul sito www.corghi.com. Una stampa responsabile aiuta a preservare l'ambiente.
To protect the planet and reduce paper usage, our catalogues are viewable online at the website www.corghi.com. Printing responsibly contributes to saving the environment.



CORGHI