







# 232 I - 232 IH

# 3,2 t

CE



-  Sollevatore elettroidraulico a due colonne
-  Electro-hydraulic 2 post lift
-  Elektrohydraulische 2-Säulen-Hebebühne
-  Pont élévateur électrohydraulique à 2 colonnes
-  Elevador electro-hidráulico





Comando a uomo presente,  
24V  
**Dead man controls,**  
24V  
Totman-Schaltung,  
24V  
Commande "homme mort",  
24V  
Mandos de hombre presente,  
24V



Dispositivo di appoggio meccanico ad inserimento automatico e disinserimento elettromagnetico a garanzia della massima sicurezza in fase di stazionamento

**Mechanical support device with automatic activation and deactivation by means of electromagnetic valve insuring maximum safety during locking procedures**

Mechanische Fallsicherung die automatisch ein- und ausrastet, gewährleistet die normkonforme Sicherheit beim Absetzen in die mechanische Fallsicherung

Dispositif d'appui mécanique à insertion automatique et désinsertion électro-magnétique pour la mise en sécurité

Dispositivo de apoyo mecánico de activación automática y desactivación electromagnética como garantía de la máxima seguridad en fase de estacionamiento

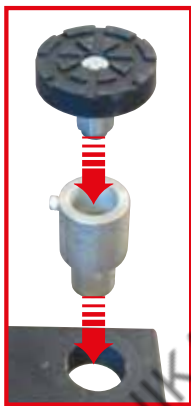

Bracci predisposti per l'alloggiamento rapido di prolunghe

**Arms suitable for quick drop-in extensions**

Aufnahmen mit Schnellstecksystem erleichtern den Einsatz von Verlängerungen.

Bras prévus pour le montage rapide de rallonges

Brazos predisuestos para el alojamiento rápido de suplementos.



Arresto bracci a inserimento automatico e sgancio automatico a terra

**Automatic locking & unlocking of arms during on floor**

Schwenkarmarretierung rastet automatisch ein (in der unteren Nullstellung) und aus (beim Heben aus der Nullstellung)

Arrêt des bras à insertion automatique et désinsertion automatique à terre

Parada de brazos de activación automática y desenganche automático de tierra



Apertura fra colonne 2.650 mm – altezza minima tamponi di soli 95 mm – bracci corti e lunghi a tre stadi, più corti in posizione chiusa per facilitare il caricamento asimmetrico di veicoli larghi e più lunghi in posizione estesa - raccomandati per il sollevamento di fuoristrada • Notevoli possibilità di regolazione dei bracci per facilitare il carico asimmetrico e la comoda apertura delle portiere • Due cilindri di sollevamento che non richiedono alcuna manutenzione. I cavi non portanti garantiscono la perfetta sincronizzazione dei carrelli indipendentemente dalla ripartizione del carico • Valvole di sicurezza nei confronti di sovraccarichi e rottura di tubi idraulici • Valvola di controllo della velocità di discesa • Funzionamento: elettroidraulico



2,65 mt span between posts • Super low 95mm. Pads • Well designed asymmetric 3 stage arms, ideal for easy undercarriage access when retracted, and perfect for long & wide vehicles when extended • Ultimate use with 4 wheel drives • Adjustable arms for easier asymmetric loading and door opening • Two lifting rams with transmission to the opposite post by means of steel rope. Non-bearing cables granting perfect synchronisation of carriages no matter what distribution weight is loaded • Safety valves protecting to prevent overloads and breakages of hydraulic hoses • Descent velocity controlled by hydraulic valve • Operation: electro-hydraulic



Säulenabstand 2650 mm - Mindestaufnahmehöhe 95 mm - Dreifach teleskopierbare kurze und lange Arme ermöglichen in geschlossener Stellung die asymmetrische Aufnahme von breiten Fahrzeugen - in ausgezogener Stellung können extra-lange Fahrzeuge aufgenommen werden - besonders geeignet zum Heben von Off-Road-Fahrzeugen • Besonders vielseitige Einstellungsmöglichkeiten der Arme gewährleisten asymmetrische Fahrzeugaufnahme und bequeme Türöffnung • Beide Hubzylinder brauchen keine Wartung. Die Gleichlaufkabel gewährleisten den einwandfreien Gleichlauf der Hubschlitzen, unabhängig der Lastverteilung • Ein Überdruckventil und eine Rohrbruchsicherung runden die Sicherheitsausstattung der Hebebühne ab • Hydraulisches Senkventil • Funktionsweise: elektrohydraulisch



Écartement entre colonnes 2650 mm – hauteur min. tampons de 95 mm seulement – bras courts et longs en trois parties, plus courts en position fermeture pour faciliter le chargement asymétrique de véhicules larges et plus longs en position étendue – recommandés pour le levage de véhicules tout-terrain • Possibilité de régler les bras pour faciliter le chargement asymétrique et l'ouverture des portes • Les deux vérins de levage ne nécessitent d'aucun entretien. Les câbles non portants assurent la synchronisation parfaite des chariots quelque que soit la distribution du poids • Clapet de surpression en cas de surcharge et rupture de tuyaux hydrauliques • Clapet de limitation vitesse de descente • Fonctionnement: électrohydraulique



Apertura entre columnas 2650 mm - altura mínima de los tacos 95 mm – brazos cortos y largos de tres estadios, más cortos en posición cerrada para facilitar la carga asimétrica de vehículos anchos y más largos en posición extendida - recomendados para la elevación de vehículos todoterreno • Notables posibilidades de regulación de los brazos para facilitar la carga asimétrica y la cómoda apertura de las puertas • Dos cilindros de elevación que no requieren ningún mantenimiento. Los cables no portantes garantizan la perfecta sincronización de los carros independientemente de la repartición de la carga • Válvulas de seguridad de sobrecargas y rotura de tubos hidráulicos • Válvula de control de la velocidad de descenso • Funcionamiento: electro-hidráulico



232 I - 232 IH

3,2 t

CE

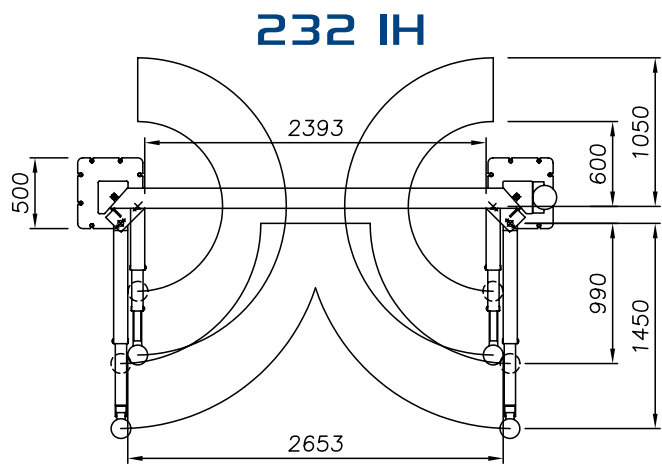
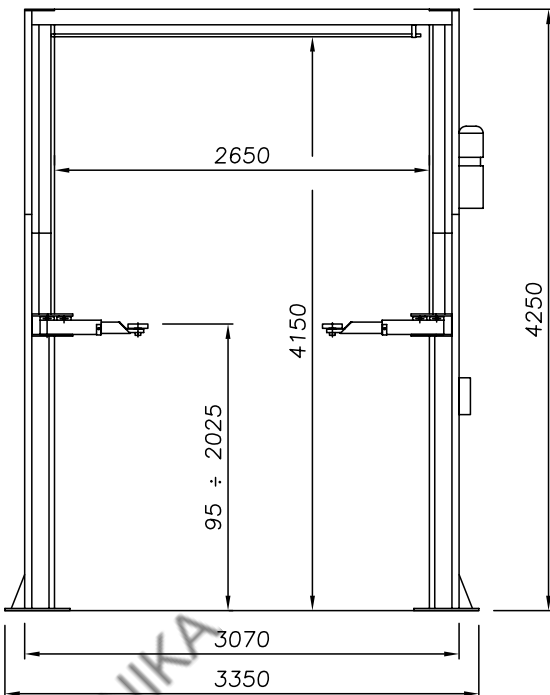
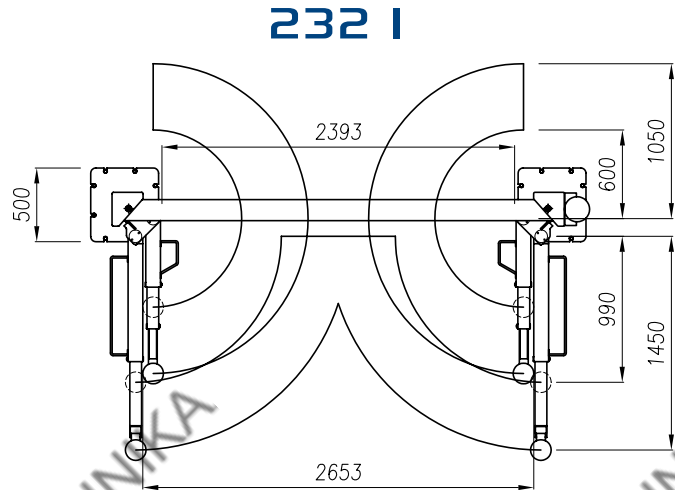
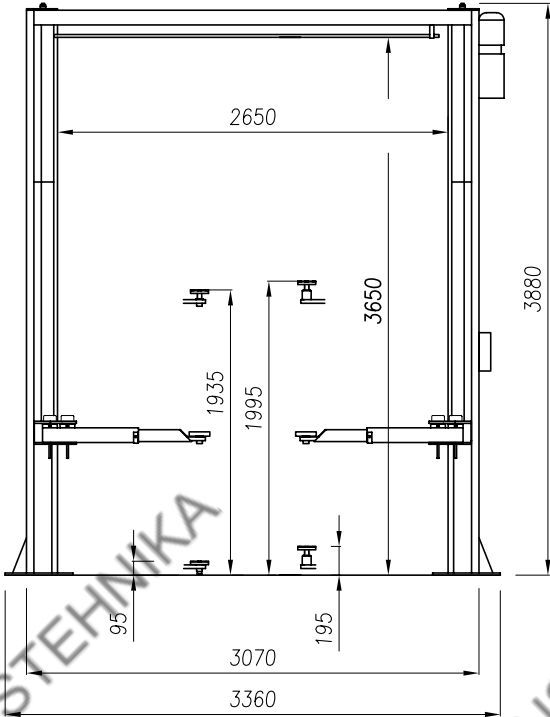



<b>Dati tecnici</b>	<b>Technical data</b>	<b>Technische Eigenschaften</b>	<b>Caractéristiques techniques</b>	<b>Datos técnicos</b>	<b>232 I</b>	<b>232 IH</b>
Portata	<b>Capacity</b>	Tragfähigkeit	Capacité	Capacidad	<b>3.200 kg</b>	<b>3.200 kg</b>
Peso	<b>Weight</b>	Gewicht	Poids	Peso	<b>700 kg</b>	<b>750 kg</b>
Salita/Discesa	<b>Lifting/lowering</b>	Hub/Senkzeit	Levage/descente	Subida/Bajada	<b>45 s</b>	<b>30 s</b>
Altezza di sollevamento	<b>Lifting height</b>	Hubhöhe	Hauteur de levage	Altura de elevación	<b>1935 mm</b>	<b>2025 mm</b>
Motore	<b>Motor</b>	Motorleistung	Puissance moteur	Motor	<b>2,2 kW - 3 ph 230-400V/50 Hz</b>	<b>2,2 kW - 3 ph 230-400V/50 Hz</b>

**Opzioni**    **Optionals**    **Sonderzubehör**    **Options**    **Opcionales**

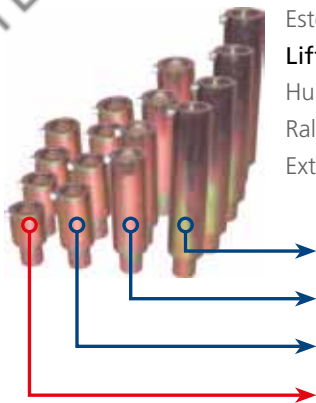

Estensioni per tamponi (kit 4 pz)  
**Lifting pad extensions (4 pcs set)**  
 Hubspindelverlängerungen (Satz 4 Stk)  
 Rallonges pour tampons (jeu de 4 pcs)  
 Extensiones para tacos (kit 4 un.)

- 250 mm (L955)
- 170 mm (L954)
- 100 mm (L953)
- 60 mm (L956 standard included)**

Esecuzione con motore monofase  
**Single-phase motor**  
 Moteur monophasé  
 Ausführung mit Einphasenmotor  
 Motor monofásico



Tamponi click system • **Click system pads** • Tragteller mit Click System • Tampons de levage click system • Tacos click system

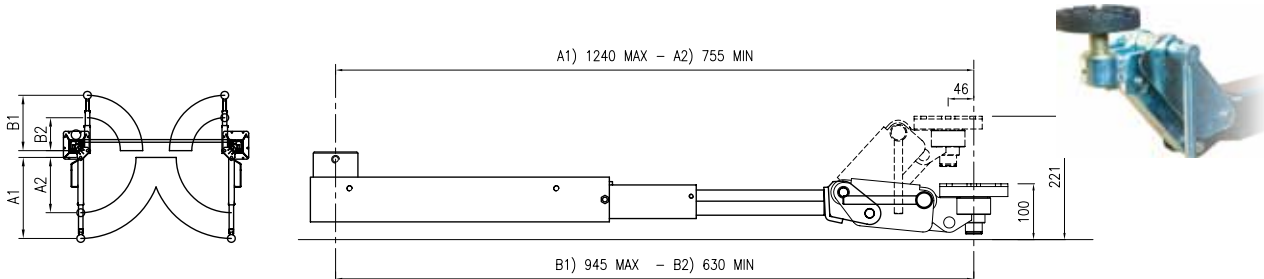

The company reserves the right to introduce improvements in design or specification without prior notice